

Wes Vice Hardwoods  
& Supply Inc.

Nederland, Texas



Crown  
Mouldings

# SPECIFICATIONS

MOULDING # CR 1

CUSTOMER: \_\_\_\_\_

COMMENTS: 20\* HOOK

MOULDER: 5/16 T-REX CORR., 1.5 START DEPTH, 10MM AXIALS  
T-REX LONG WEAR

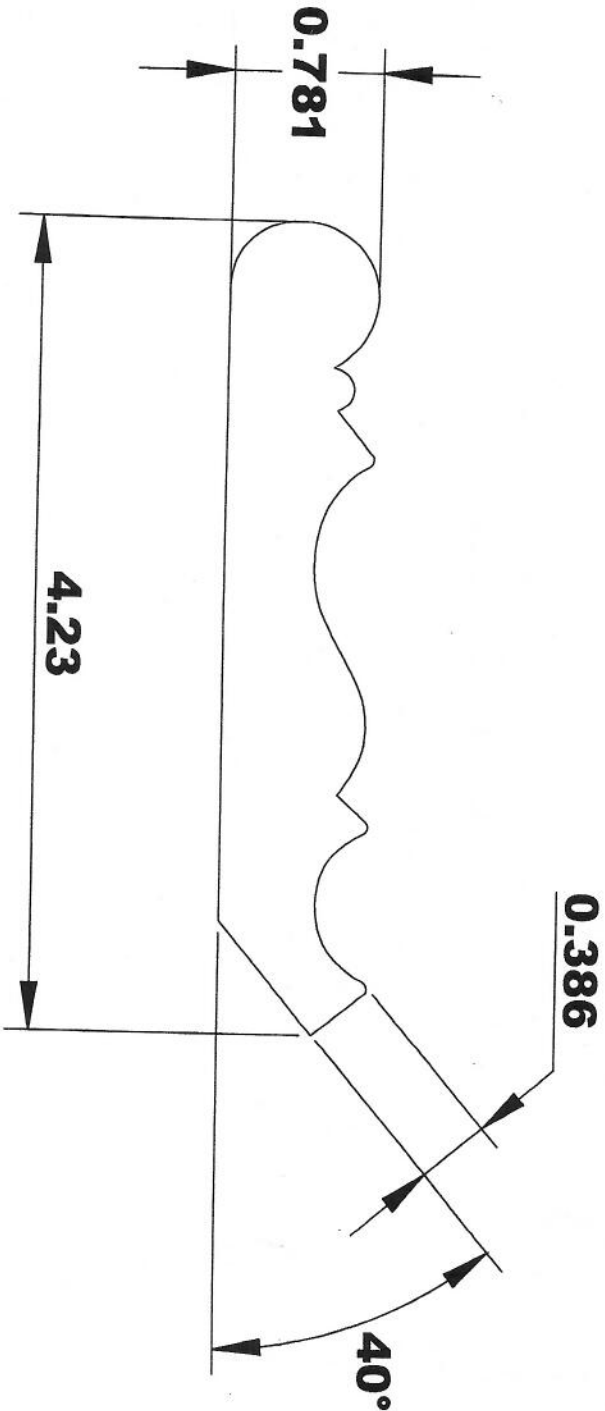

INSIDE OF MACHINE

OUTFEED VIEW COMING

# SPECIFICATIONS

MOULDING # CR 1

CUSTOMER: DUAL ANGLE

COMMENTS: 20\* HOOK

MOULDER: 5/16 T-REX CORR., 1.5 START DEPTH, 10MM AXIALS  
T-REX LONG WEAR

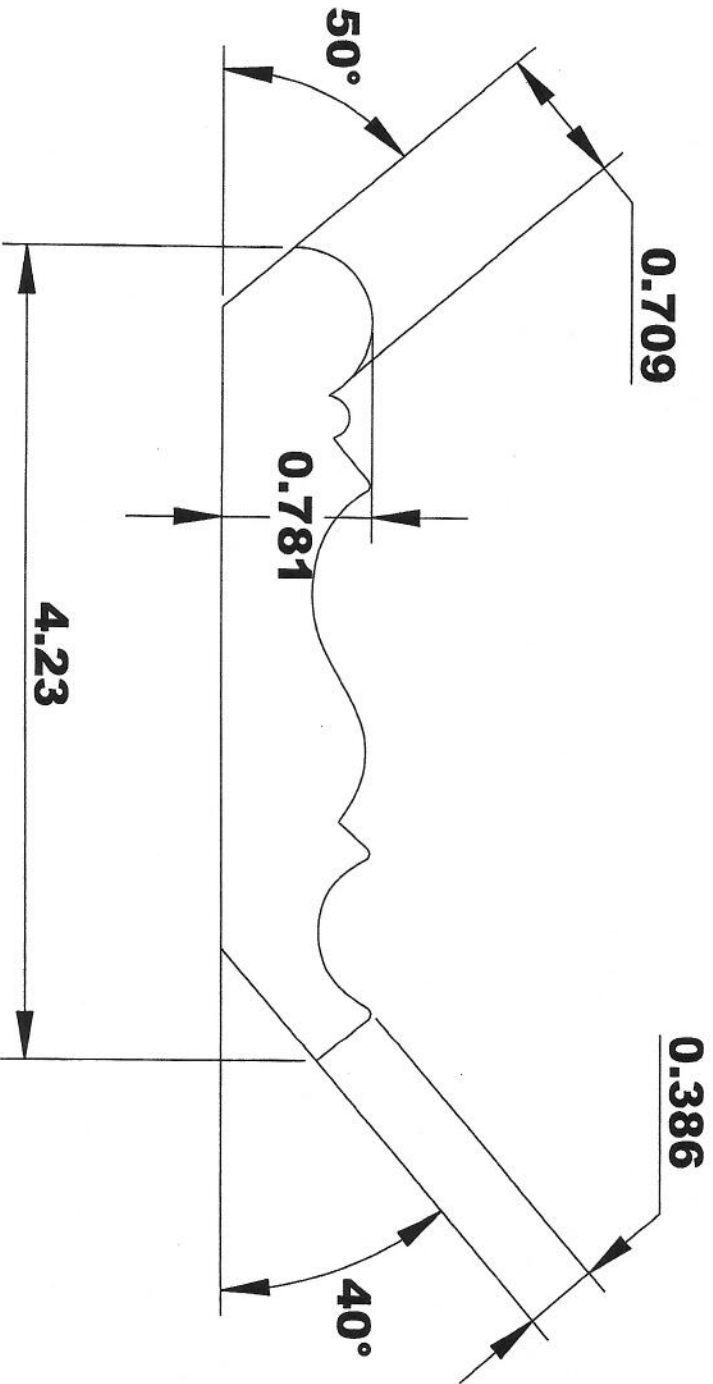

INSIDE OF MACHINE

OUTFEED VIEW COMING

# SPECIFICATIONS

MOULDING # **CR 2**

CUSTOMER: \_\_\_\_\_

COMMENTS: **20\* HOOK**

MOULDER: 5/16 T-REX CORR., 1.5 START DEPTH, 10MM AXIALS  
T-REX LONG WEAR

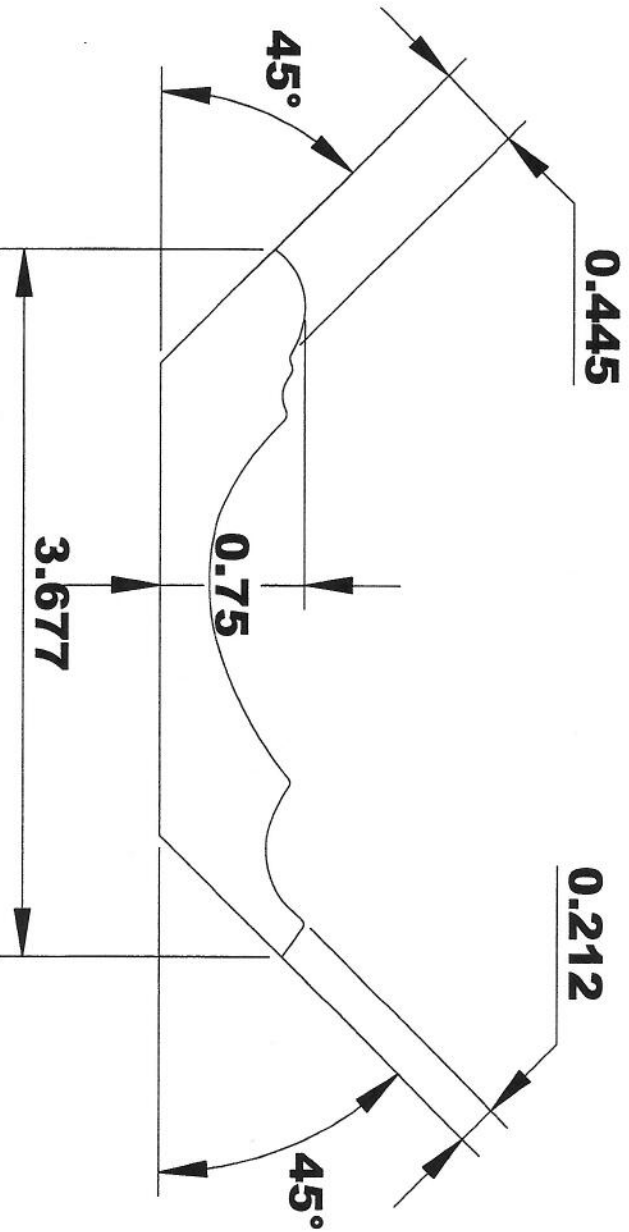

INSIDE OF MACHINE

OUTFEED VIEW COMING

# SPECIFICATIONS

MOULDING # CR 3

CUSTOMER: \_\_\_\_\_

COMMENTS: 20 \* HOOK

MOULDER: 5/16 T-REX CORR., 1.5 START DEPTH, 10MM AXIALS  
T-REX LONG WEAR

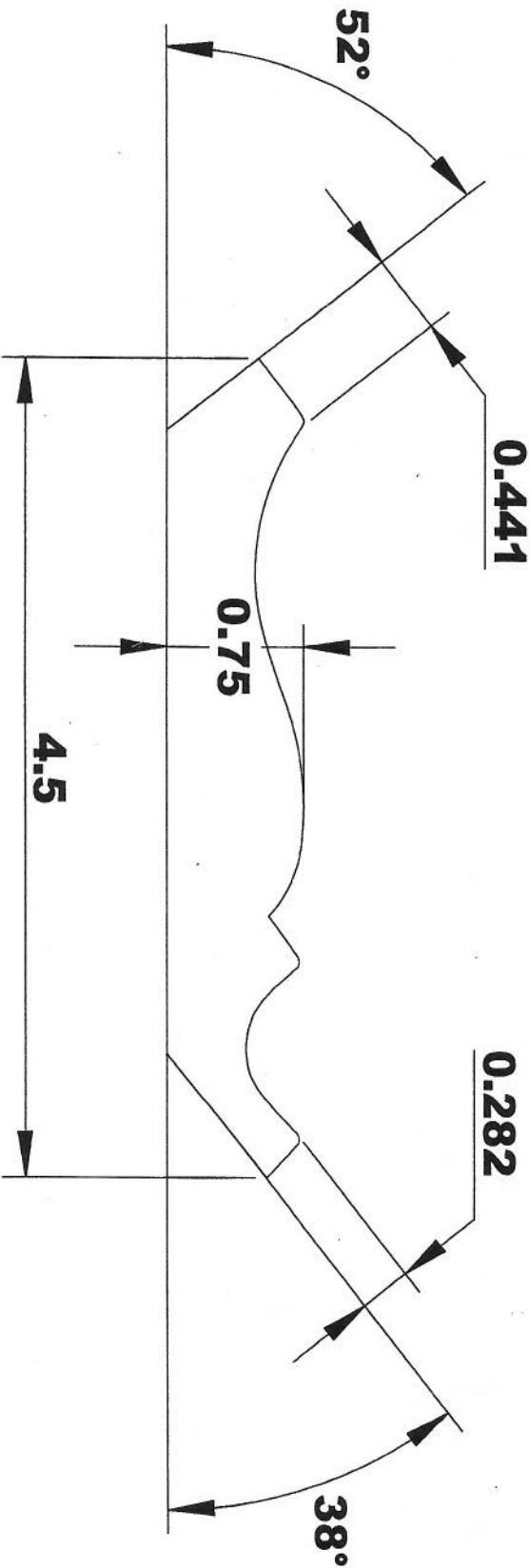

INSIDE OF MACHINE

OUTFEED VIEW COMING

# SPECIFICATIONS

MOULDING # CR 4

CUSTOMER: \_\_\_\_\_

COMMENTS: 20\* HOOK

MOULDER: 5/16 T-REX CORR., 1.5 START DEPTH, 10MM AXIALS  
T-REX LONG WEAR

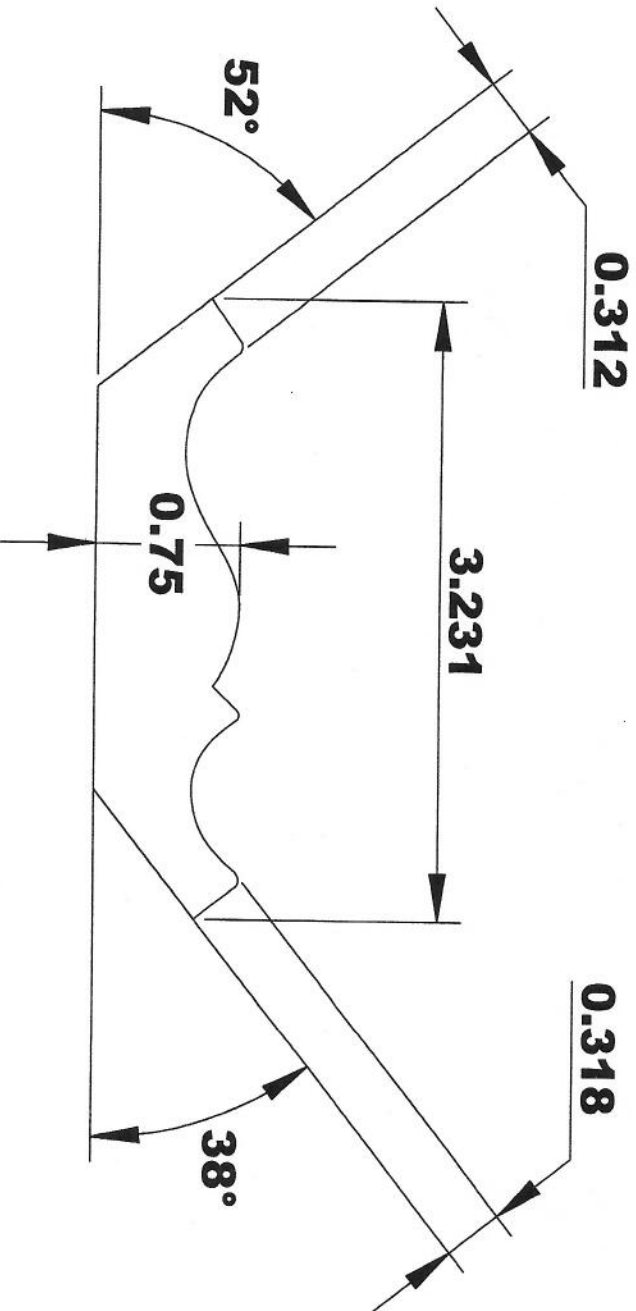

USE CR 3 SIDE KNIVES

INSIDE OF MACHINE

OUTFEED VIEW COMING

# SPECIFICATIONS

MOULDING # **CR 5**

CUSTOMER: \_\_\_\_\_

COMMENTS: **20 \* HOOK**

MOULDER: 5/16 T-REX CORR., 1.5 START DEPTH, 10MM AXIALS  
T-REX LONG WEAR

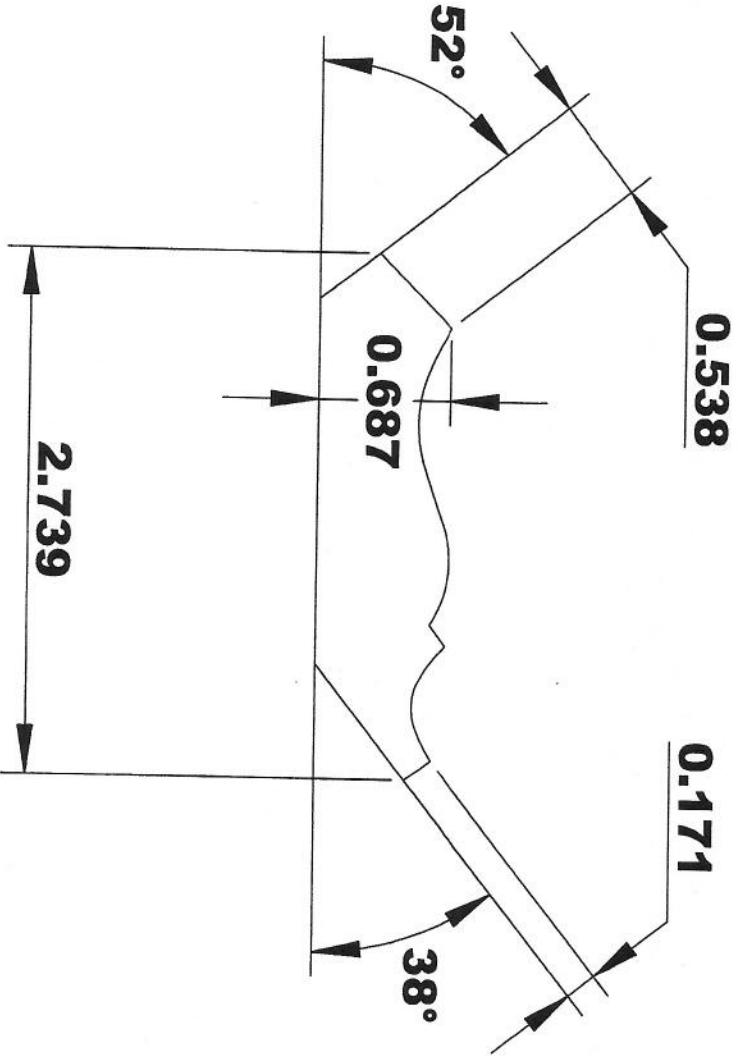

INSIDE OF MACHINE

OUTFEED VIEW COMING

# SPECIFICATIONS

MOULDING # CR 6

CUSTOMER: \_\_\_\_\_

COMMENTS: 20\* HOOK

MOULDER: 5/16 T-REX CORR., 1.5 START DEPTH, 10MM AXIALS  
T-REX LONG WEAR

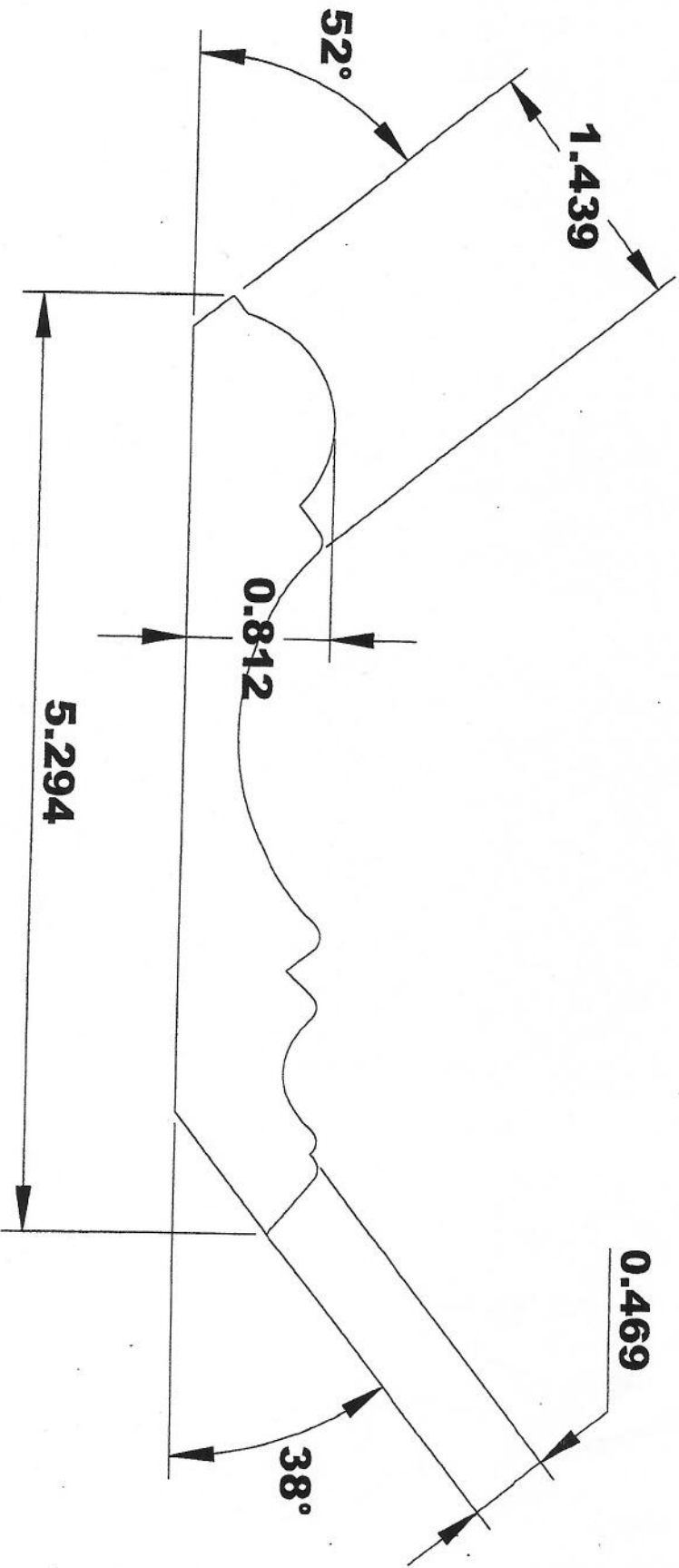

INSIDE OF MACHINE

OUTFEED VIEW COMING



# SPECIFICATIONS

MOULDING # **CR 7**

CUSTOMER: \_\_\_\_\_

COMMENTS: **20\* HOOK**

MOULDER: 5/16 T-REX CORR., 1.5 START DEPTH, 10MM AXIALS  
T-REX LONG WEAR

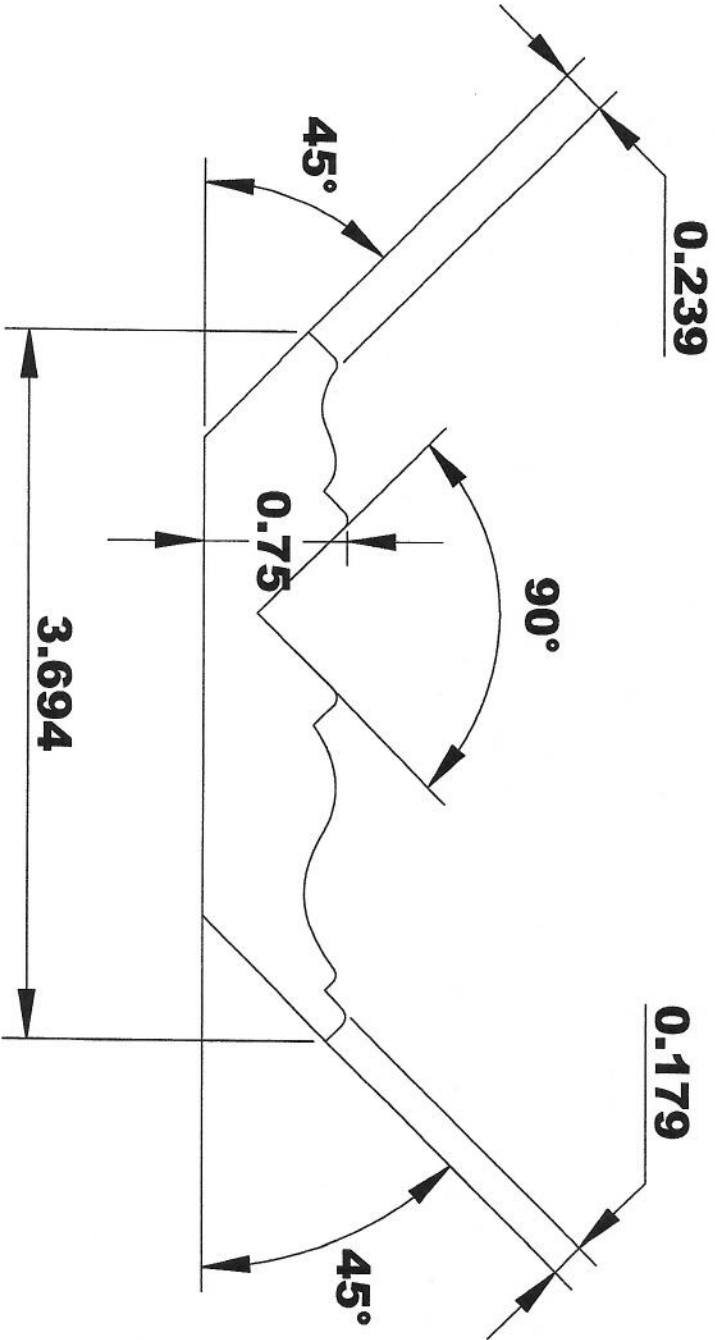

CAN USE CR 2 SIDE KNIVES, 45\*S

INSIDE OF MACHINE

OUTFEED VIEW COMING

# SPECIFICATIONS

MOULDING # CR 8

CUSTOMER: \_\_\_\_\_

COMMENTS: 20 \* HOOK

MOULDER: 5/16 T-REX CORR., 1.5 START DEPTH, 10MM AXIALS  
T-REX LONG WEAR

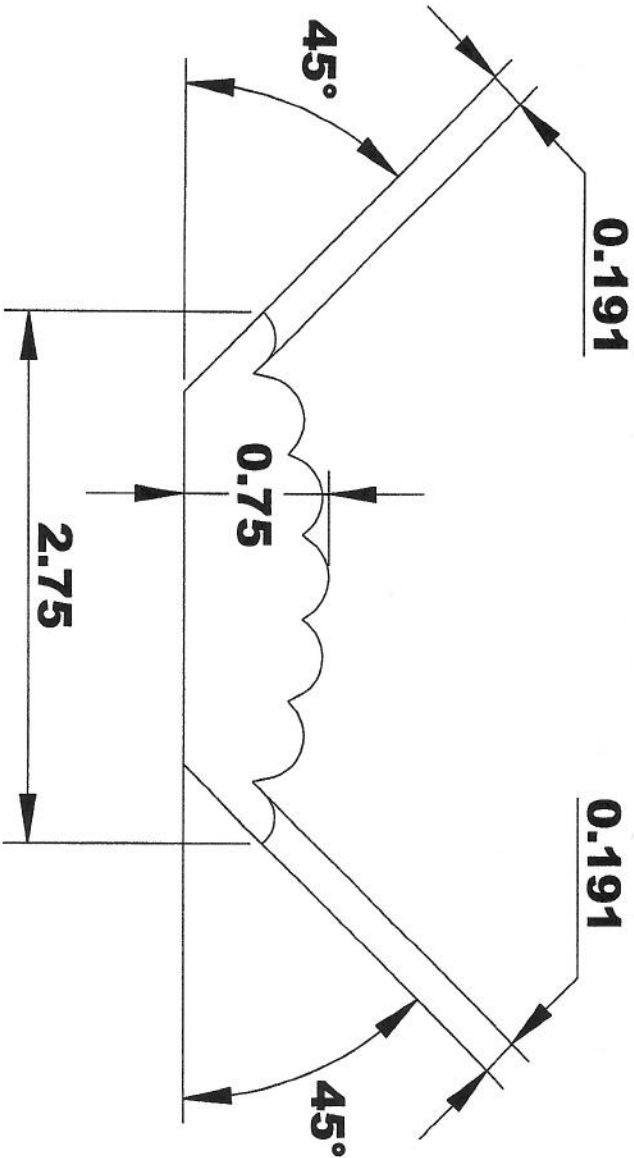

NOTE: MAKE SYMMETRICAL

INSIDE OF MACHINE

OUTFEED VIEW COMING

# SPECIFICATIONS

MOULDING # **CR 9**

CUSTOMER: \_\_\_\_\_

COMMENTS: **20\* HOOK**

MOULDER: 5/16 T-REX CORR., 1.5 START DEPTH, 10MM AXIALS  
T-REX LONG WEAR

NOTE: MAKE SYMMETRICAL

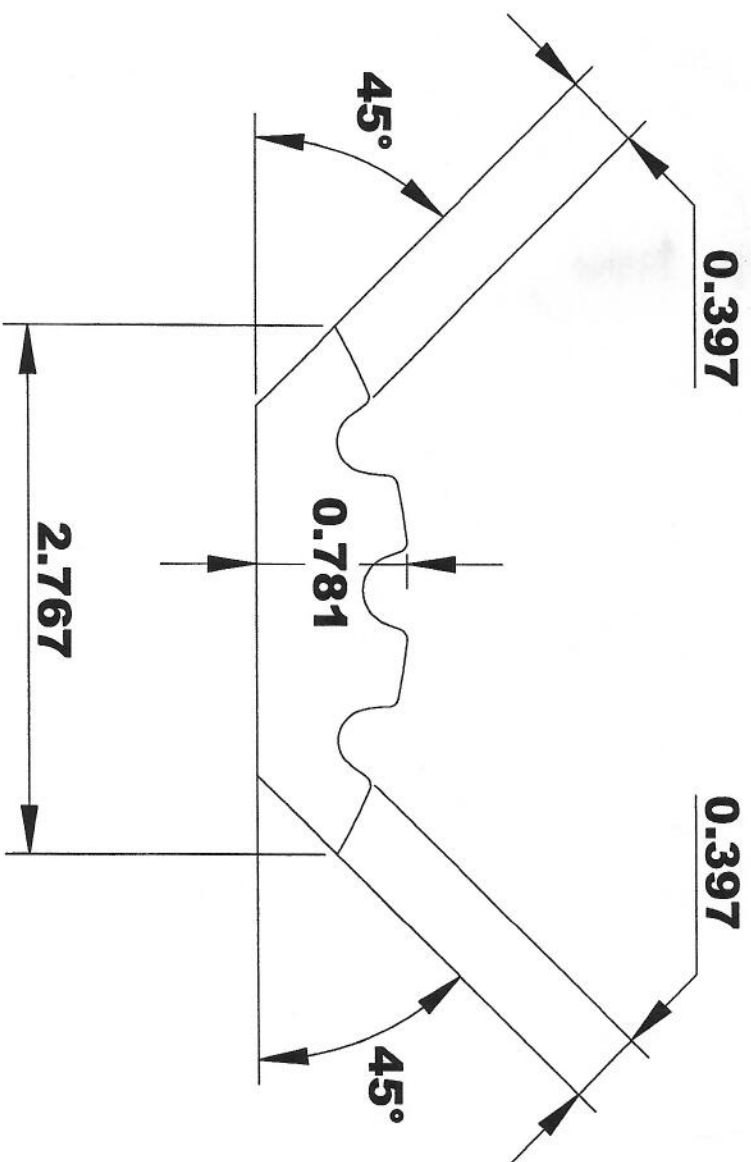

INSIDE OF MACHINE

OUTFEED VIEW COMING

# SPECIFICATIONS

MOULDING # **CR 10**

CUSTOMER: \_\_\_\_\_

COMMENTS: **20\* HOOK**

MOULDER: 5/16 T-REX CORR., 1.5 START DEPTH, 10MM AXIALS  
T-REX LONG WEAR

NOTE: MAKE SYMMETRICAL

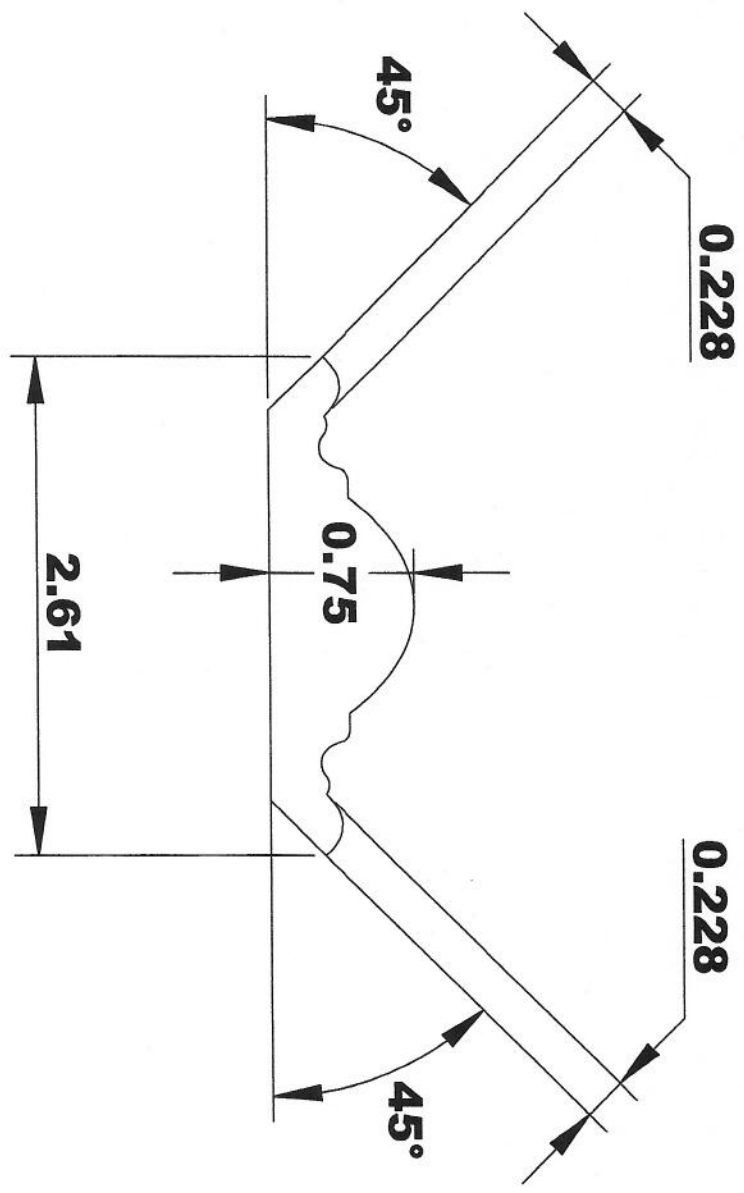

INSIDE OF MACHINE

OUTFEED VIEW COMING

# SPECIFICATIONS

MOULDING # **CR 11**

CUSTOMER: \_\_\_\_\_

COMMENTS: **20 \* HOOK**

MOULDER: 5/16 T-REX CORR., 1.5 START DEPTH, 10MM AXIALS

T-REX LONG WEAR

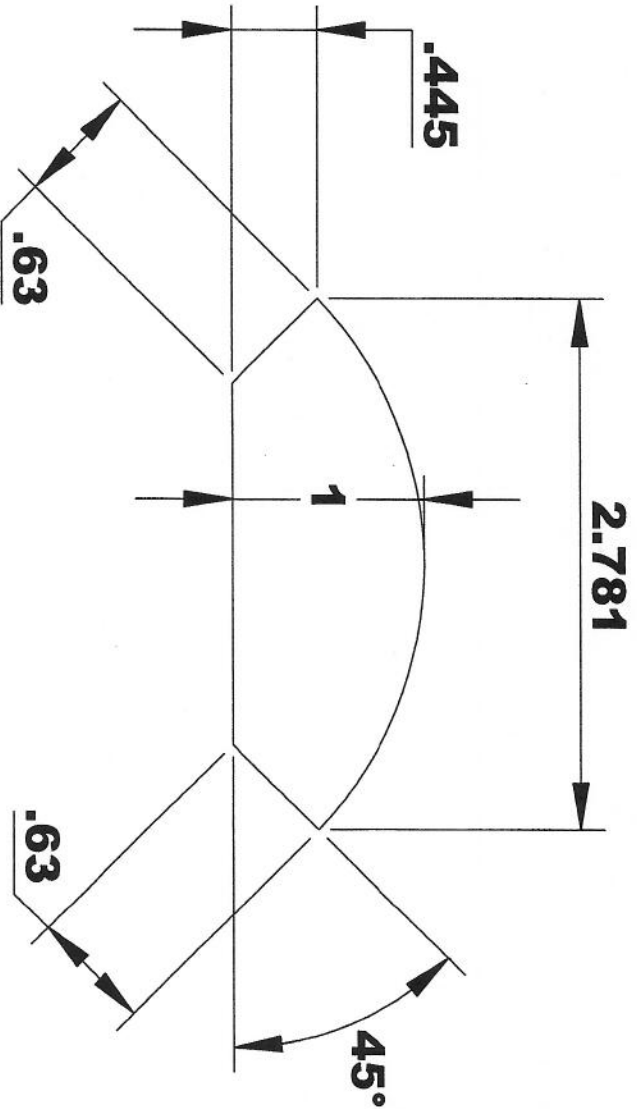
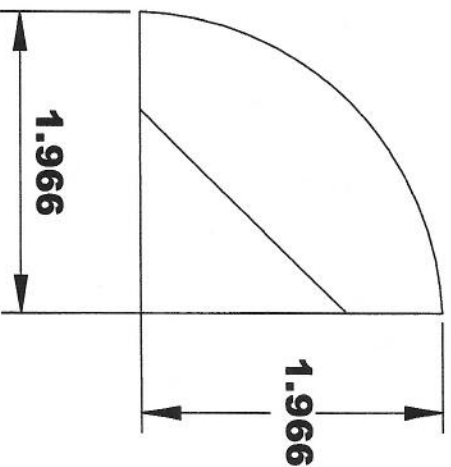

NOTE: DESIGN IS SYMMETRICAL

INSIDE OF MACHINE

OUTFEED VIEW COMING

# SPECIFICATIONS

MOULDING # **CR 12**

CUSTOMER: \_\_\_\_\_

COMMENTS: **20\* HOOK**

MOULDER: 5/16 T-REX CORR., 1.5 START DEPTH, 10MM AXIALS  
T-REX LONG WEAR

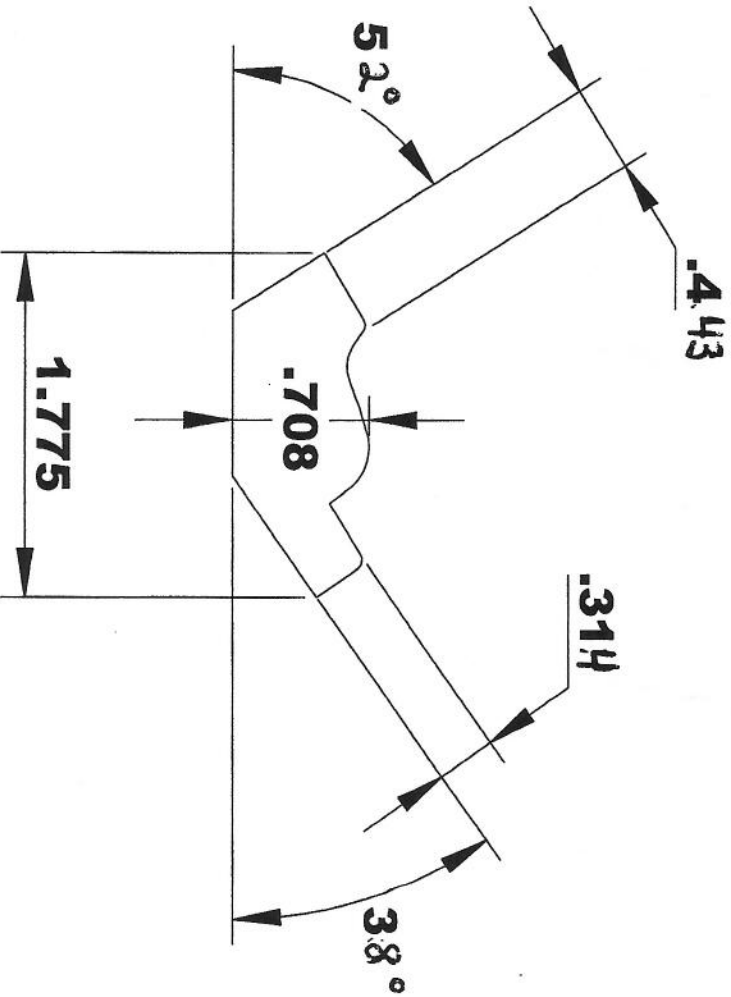

INSIDE OF MACHINE

OUTFEED VIEW COMING

# SPECIFICATIONS

MOULDING # **CR 13**

CUSTOMER: \_\_\_\_\_

COMMENTS: **20° HOOK**

MOULDER: 5/16 T-REX CORR., 1.5 START DEPTH, 10MM AXIALS

T-REX LONG WEAR

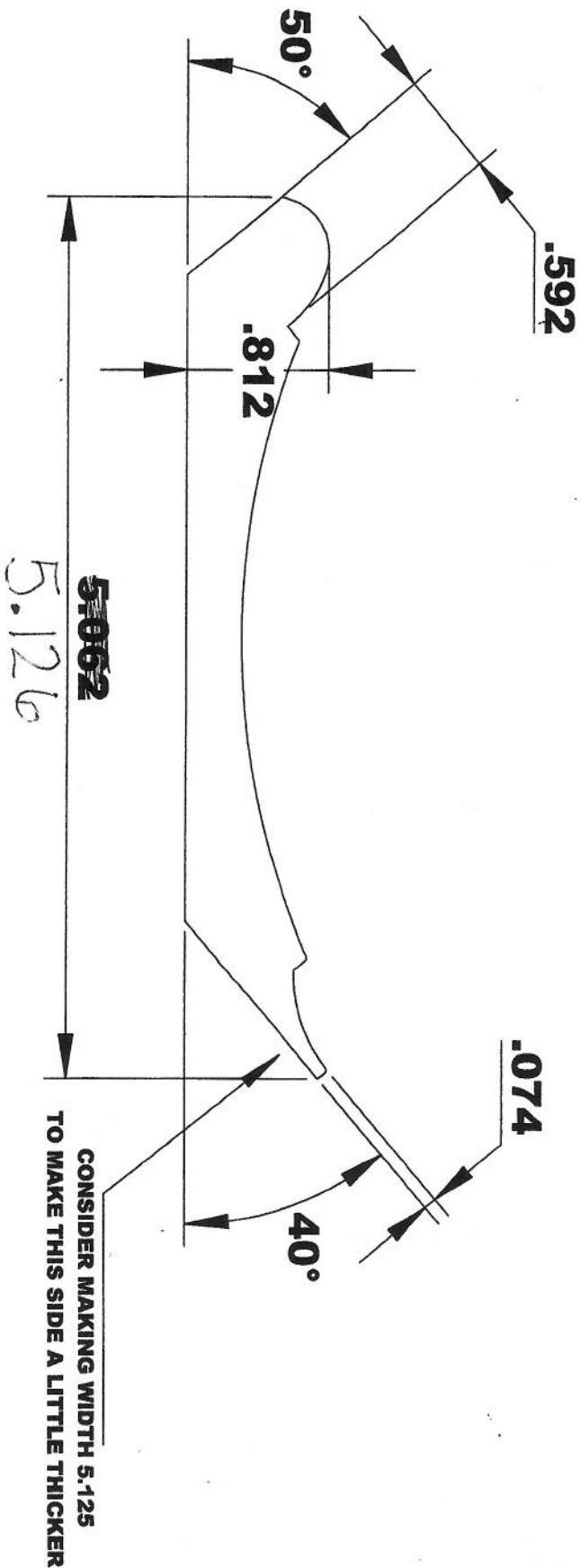
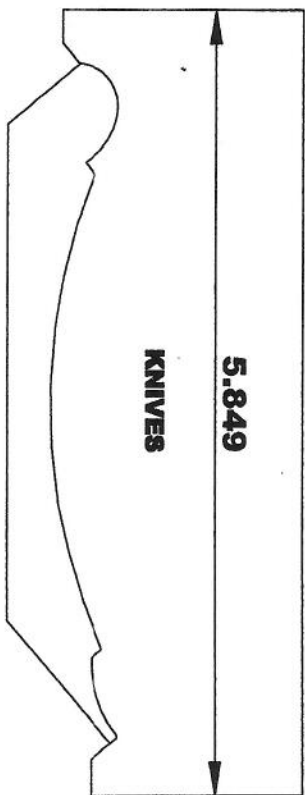

INSIDE OF MACHINE

OUTFEED VIEW COMING

# SPECIFICATIONS

MOULDING # **CR 14**

CUSTOMER: \_\_\_\_\_

COMMENTS: **20\* HOOK**

MOULDER: 5/16 T-REX CORR., 1.5 START DEPTH, 10MM AXIALS

T-REX LONG WEAR

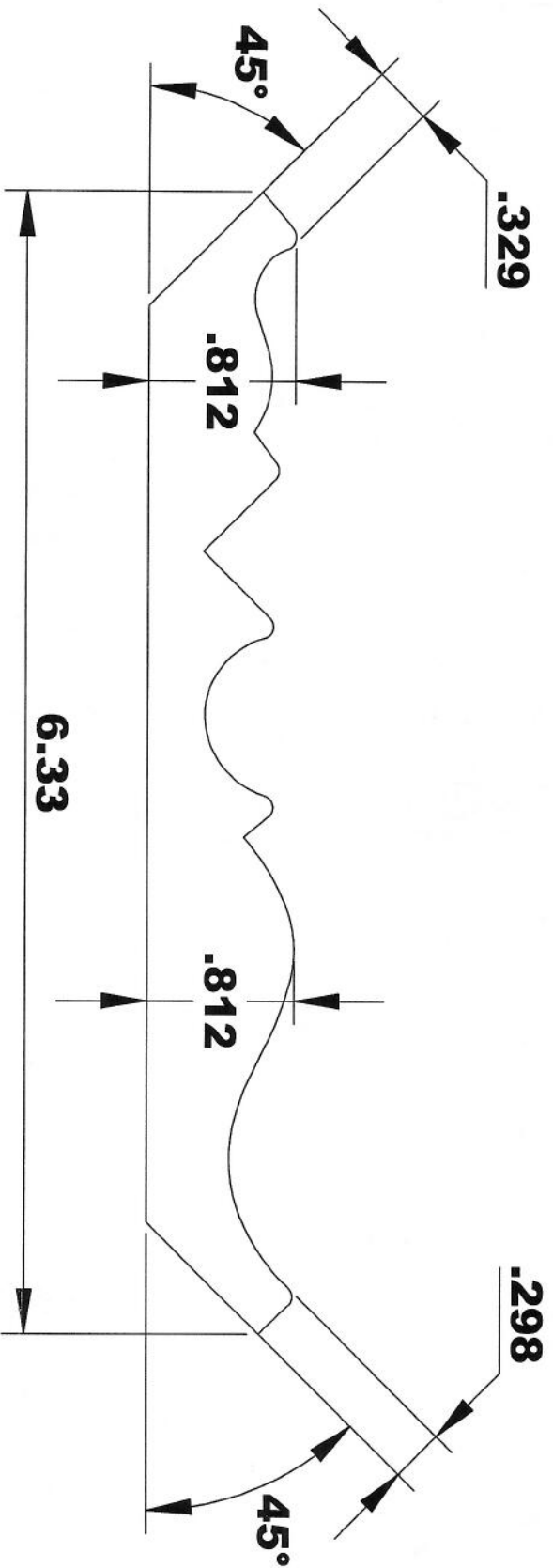

INSIDE OF MACHINE

OUTFEED VIEW COMING



# SPECIFICATIONS

MOULDING # **CR 15**

CUSTOMER: \_\_\_\_\_

COMMENTS: **20\* HOOK**

MOULDER: 5/16 T-REX CORR., 1.5 START DEPTH, 10MM AXIALS

T-REX LONG WEAR

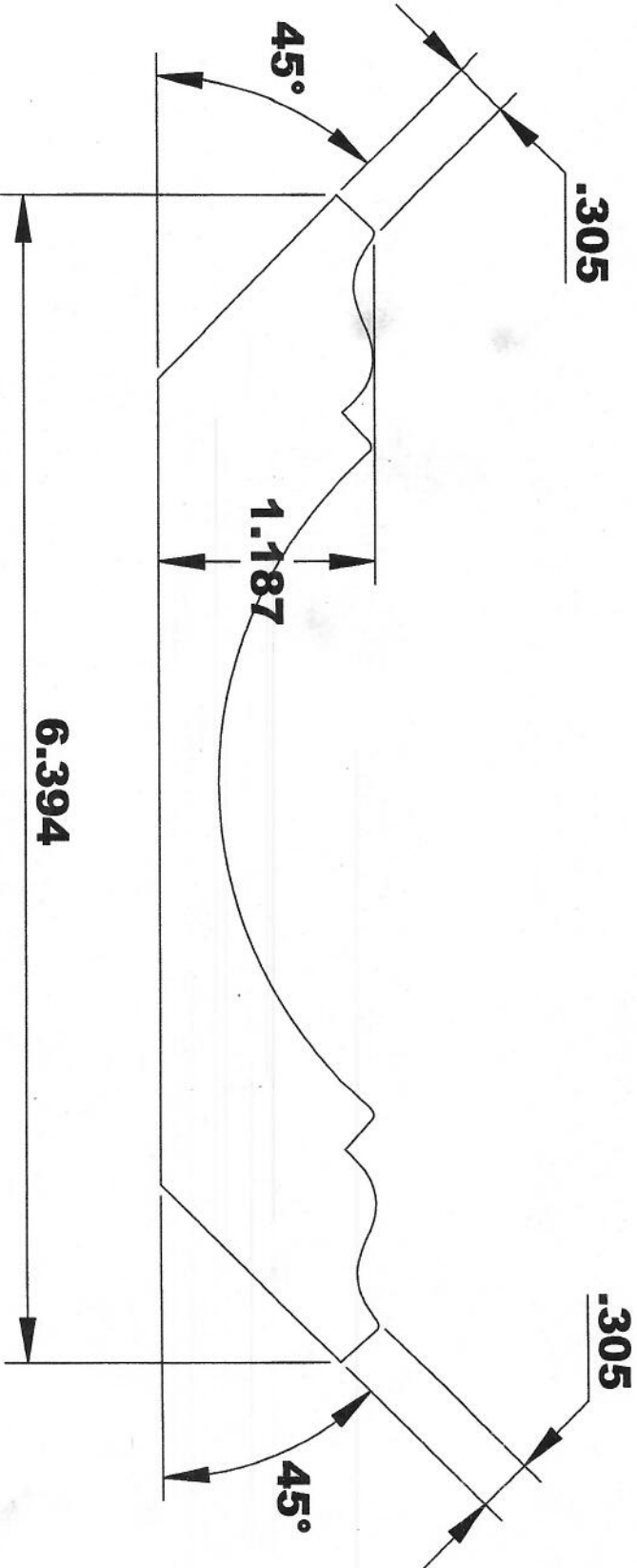

INSIDE OF MACHINE

OUTFEED VIEW COMING

# SPECIFICATIONS

MOULDING # CR 16

CUSTOMER: \_\_\_\_\_

COMMENTS: 20\* HOOK

MOULDER: 5/16 T-REX CORR., 1.5 START DEPTH, 10MM AXIALS  
T-REX LONG WEAR

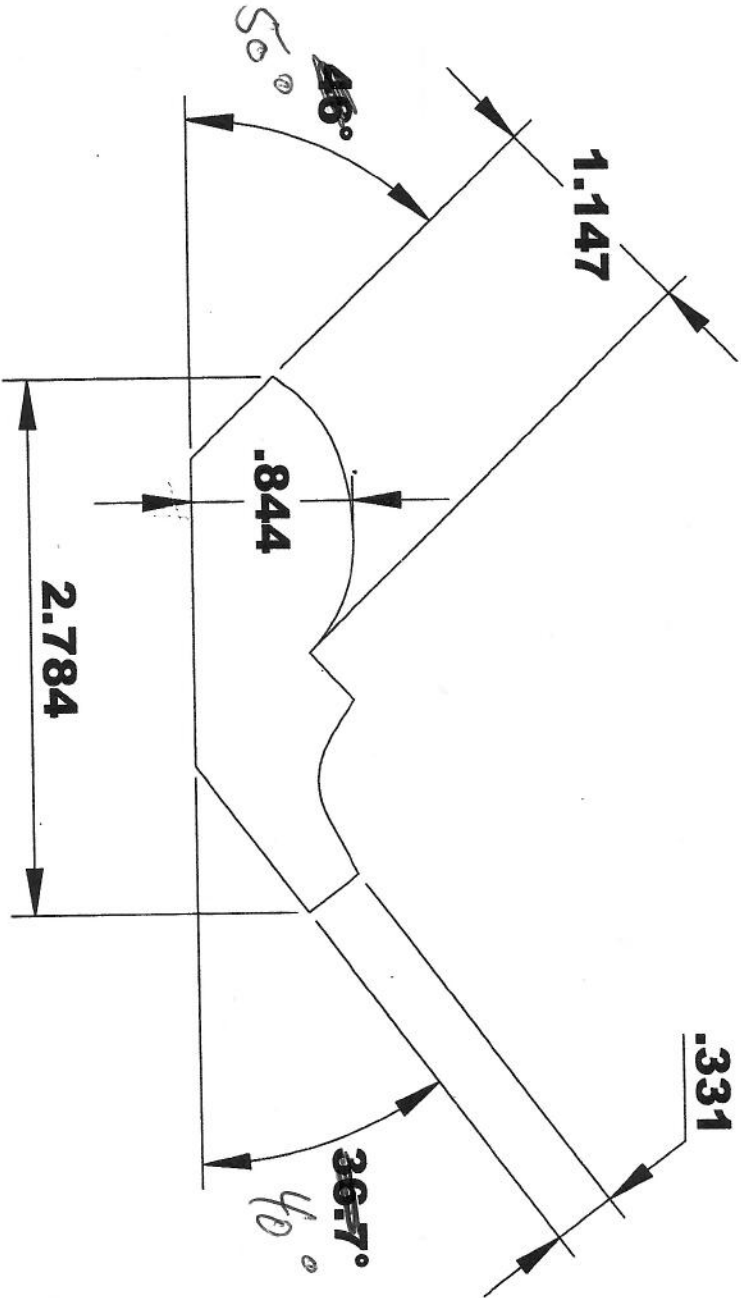

INSIDE OF MACHINE

OUTFEED VIEW COMING

# SPECIFICATIONS

MOULDING # **CR 17**

CUSTOMER: \_\_\_\_\_

COMMENTS: **20\* HOOK**

MOULDER: 5/16 T-REX CORR., 1.5 START DEPTH, 10MM AXIALS  
T-REX LONG WEAR

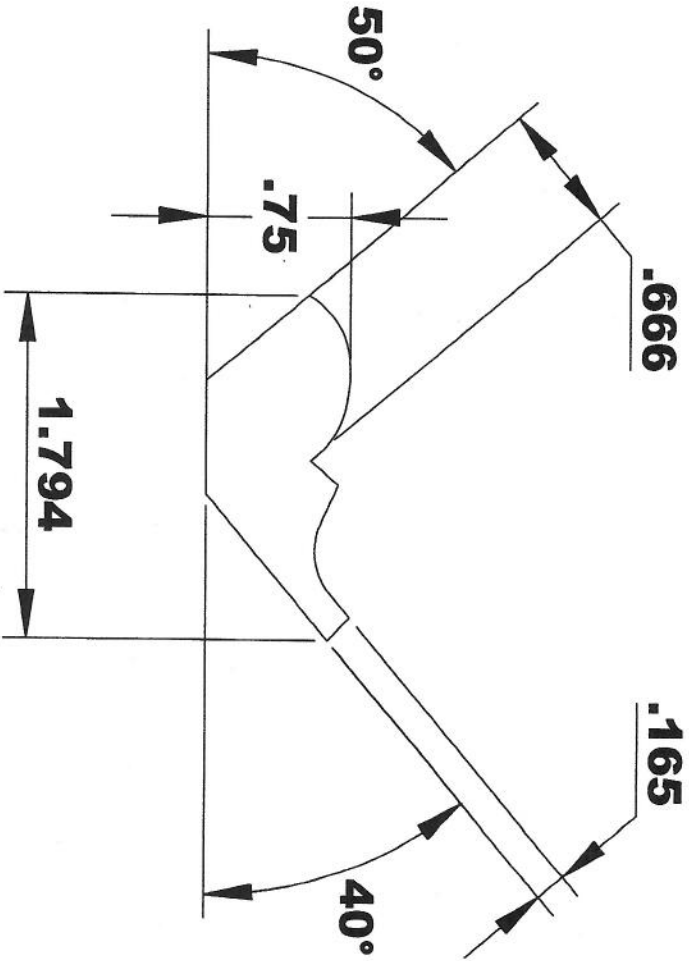

INSIDE OF MACHINE

OUTFEED VIEW COMING

# SPECIFICATIONS

MOULDING # CR 18

CUSTOMER: \_\_\_\_\_

COMMENTS: 20\* HOOK

MOULDER: 5/16 T-REX CORR., 1.5 START DEPTH, 10MM AXIALS

T-REX LONG WEAR

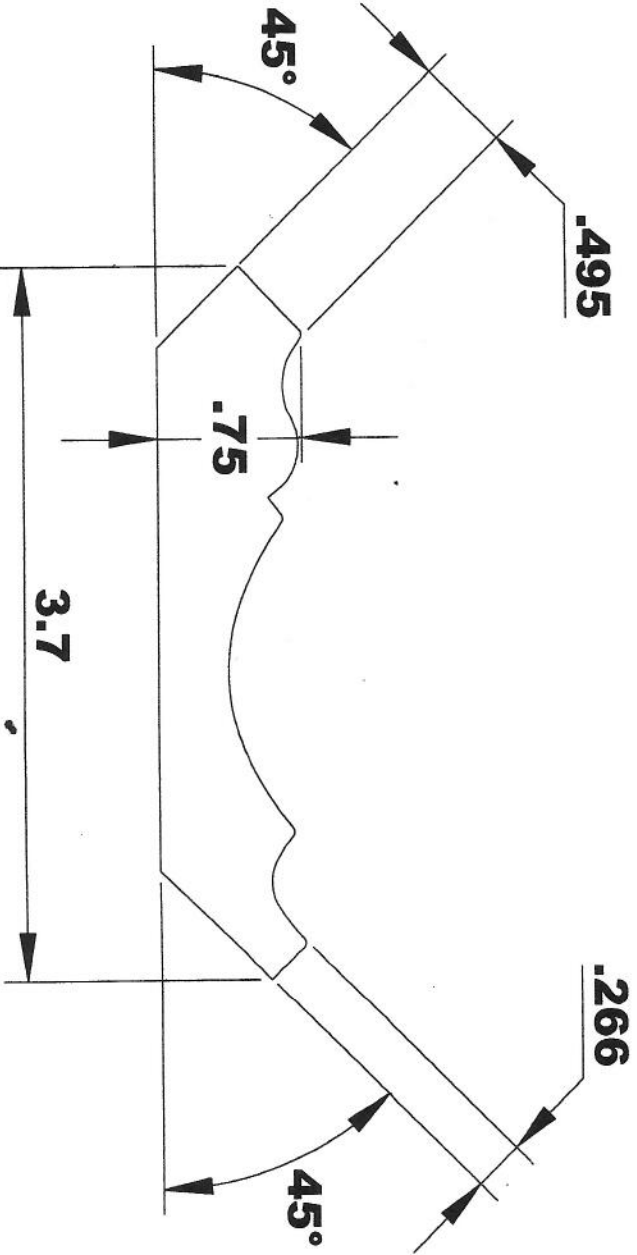

INSIDE OF MACHINE

OUTFEED VIEW COMING

# SPECIFICATIONS

MOULDING # **CR 19**

CUSTOMER: \_\_\_\_\_

COMMENTS: **20\* HOOK**

MOULDER: 5/16 T-REX CORR., 1.5 START DEPTH, 10MM AXIALS

T-REX LONG WEAR

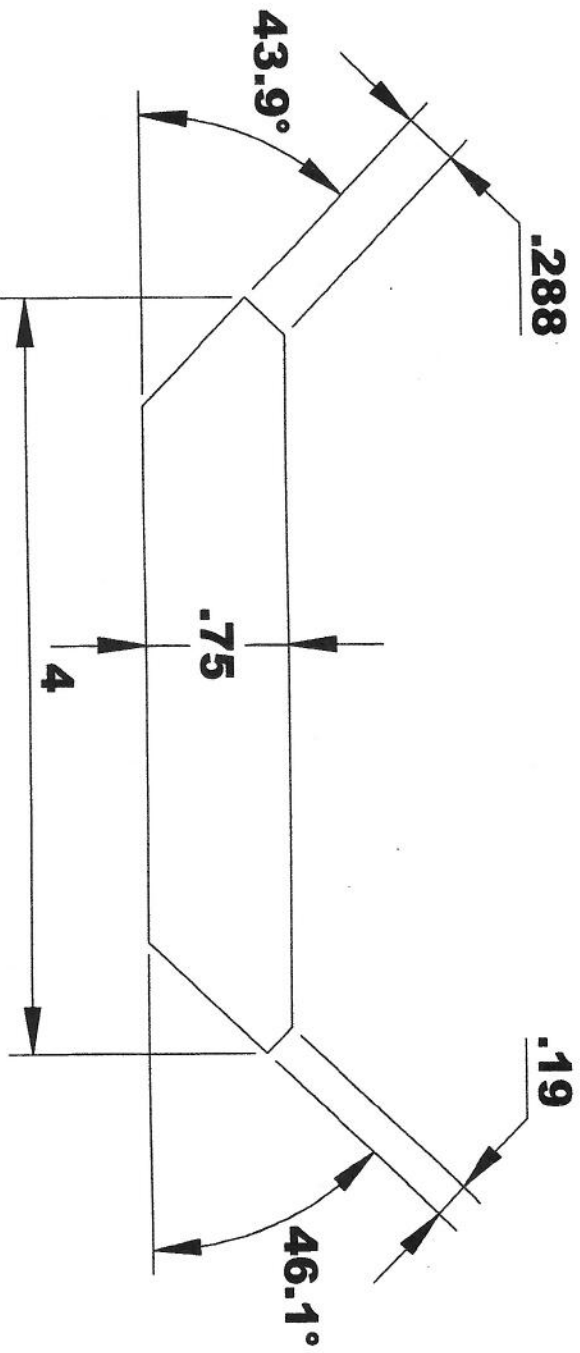

INSIDE OF MACHINE

OUTFEED VIEW COMING

# SPECIFICATIONS

MOULDING # CR 20

CUSTOMER: \_\_\_\_\_

COMMENTS: 20\* HOOK

MOULDER: 5/16 T-REX CORR., 1.5 START DEPTH, 10MM AXIALS  
T-REX LONG WEAR

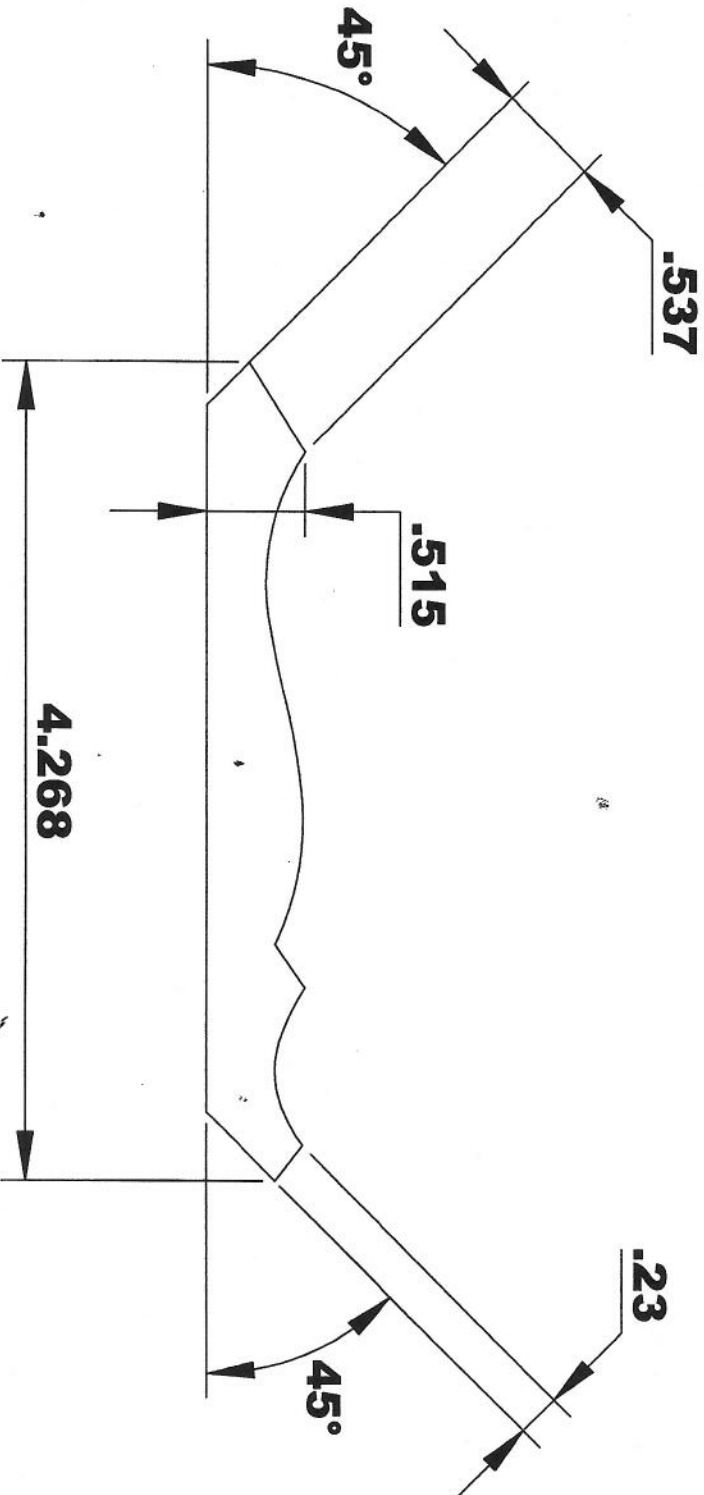

INSIDE OF MACHINE

OUTFEED VIEW COMING

# SPECIFICATIONS

MOULDING # **CR 21**

CUSTOMER: \_\_\_\_\_

COMMENTS: **20° HOOK**

MOULDER: 5/16 T-REX CORR., 1.5 START DEPTH, 10MM AXIALS  
T-REX LONG WEAR

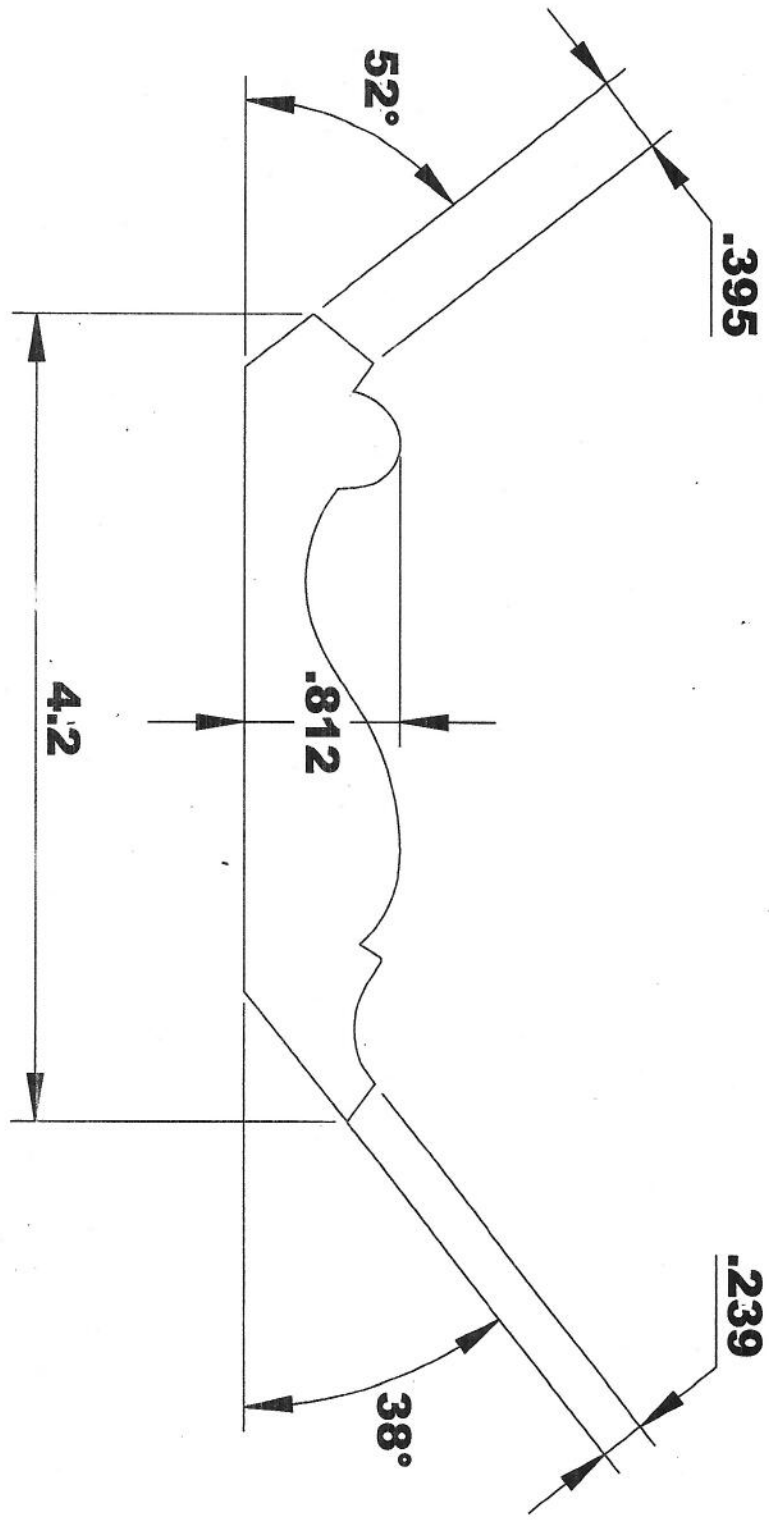

INSIDE OF MACHINE

OUTFEED VIEW COMING

# SPECIFICATIONS

MOULDING # CR 22

CUSTOMER: \_\_\_\_\_

COMMENTS: 20 \* HOOK

MOULDER: 5/16 T-REX CORR., 1.5 START DEPTH, 10MM AXIALS

T-REX LONG WEAR

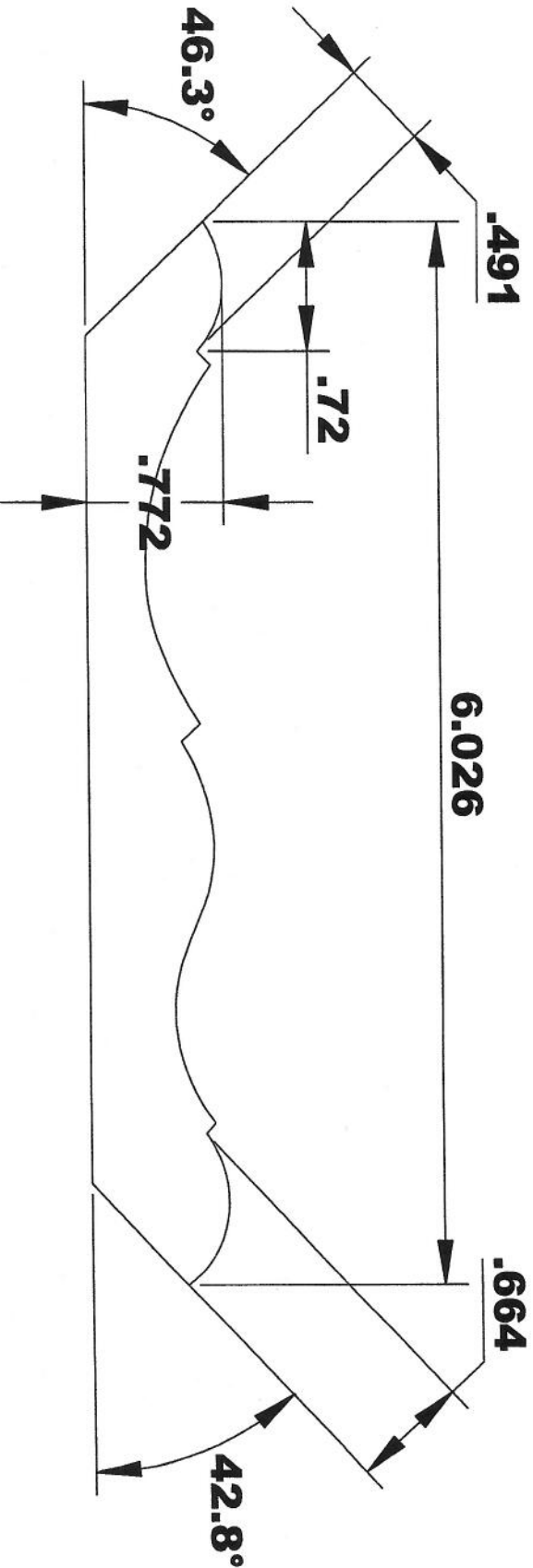

INSIDE OF MACHINE

OUTFEED VIEW COMING



# SPECIFICATIONS

MOULDING # **CR 23**

CUSTOMER: \_\_\_\_\_

COMMENTS: **20° HOOK**

MOULDER: 5/16 T-REX CORR., 1.5 START DEPTH, 10MM AXIALS  
T-REX LONG WEAR

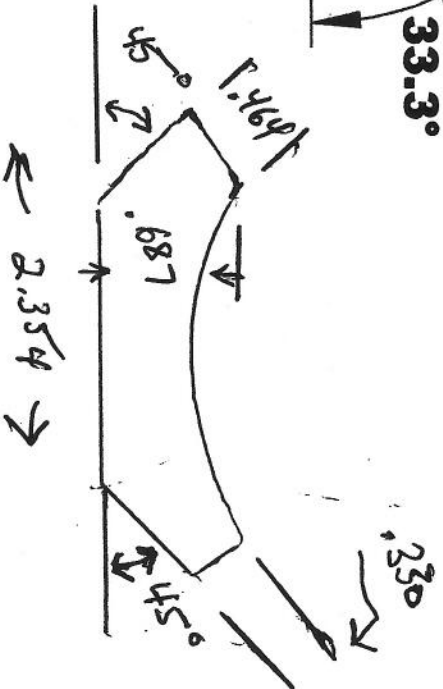
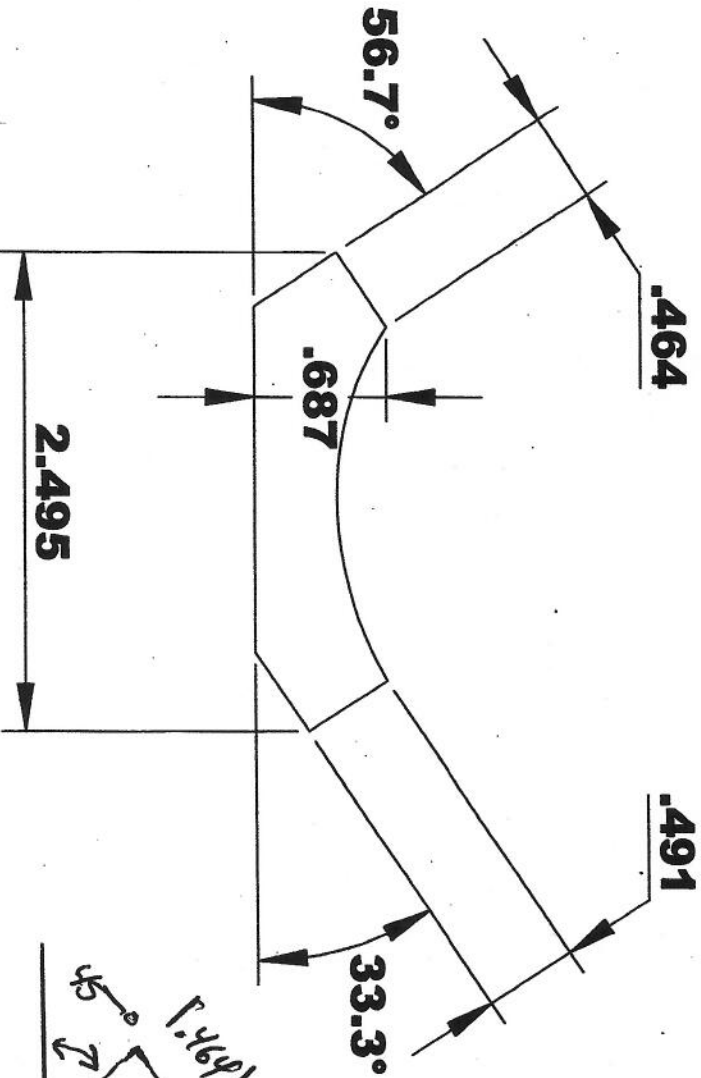
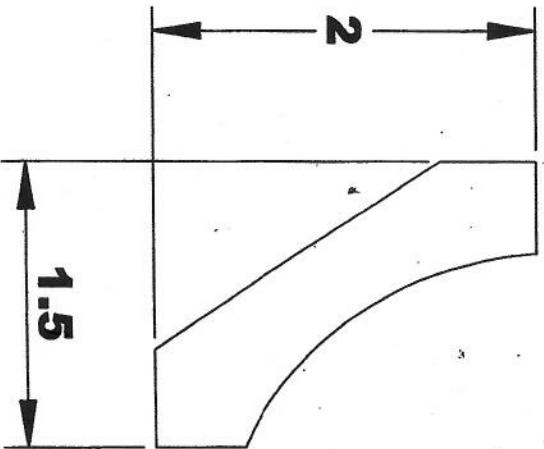

INSIDE OF MACHINE

OUTFEED VIEW COMING

# SPECIFICATIONS

MOULDING # **CR 24**

CUSTOMER: \_\_\_\_\_

COMMENTS: **20\* HOOK**

MOULDER: 5/16 T-REX CORR., 1.5 START DEPTH, 10MM AXIALS  
T-REX LONG WEAR

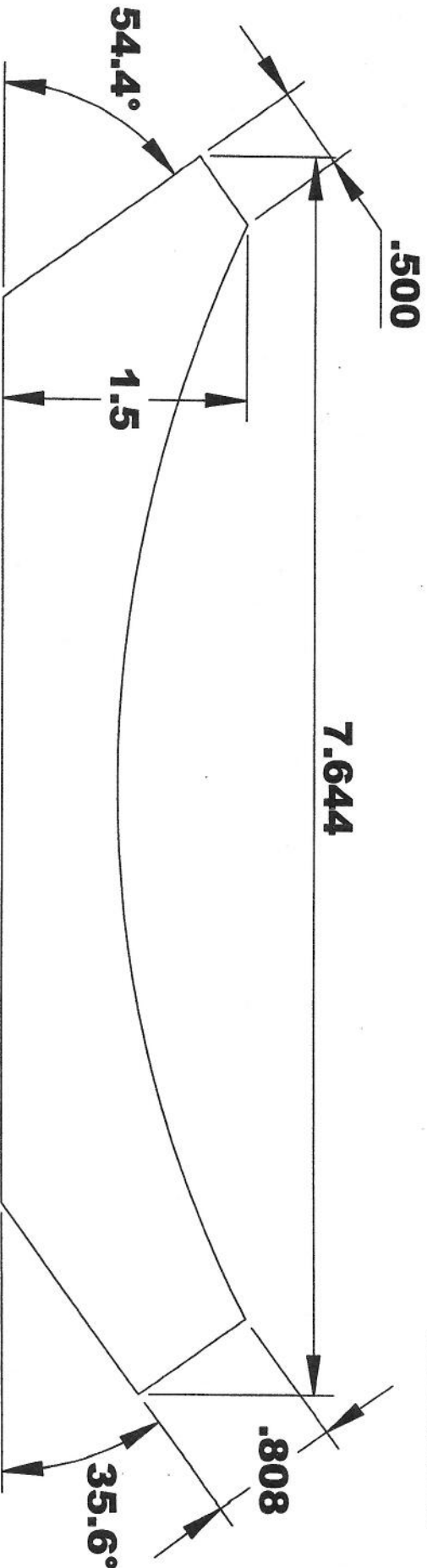
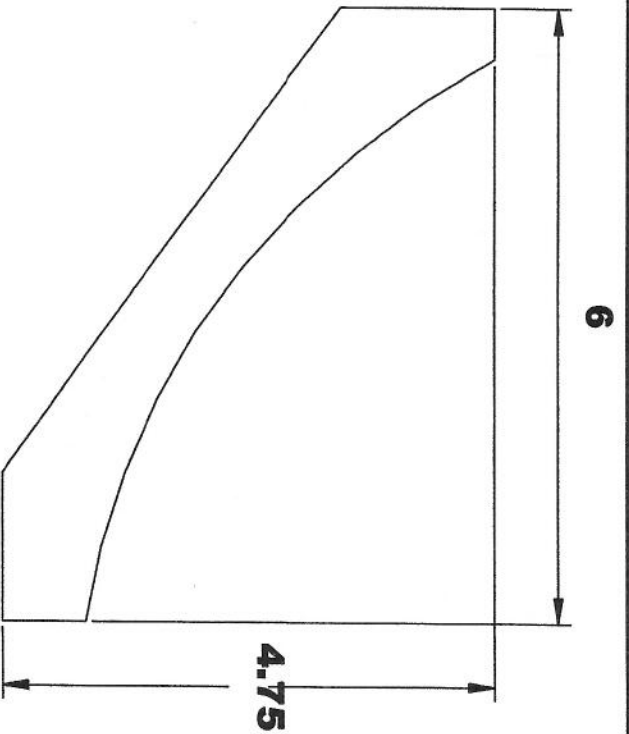

INSIDE OF MACHINE

OUTFEED VIEW COMING

# SPECIFICATIONS

MOULDING # CR 25

CUSTOMER: \_\_\_\_\_

COMMENTS: 20\* HOOK

MOULDER: 5/16 T-REX CORR., 1.5 START DEPTH, 10MM AXIALS

T-REX LONG WEAR

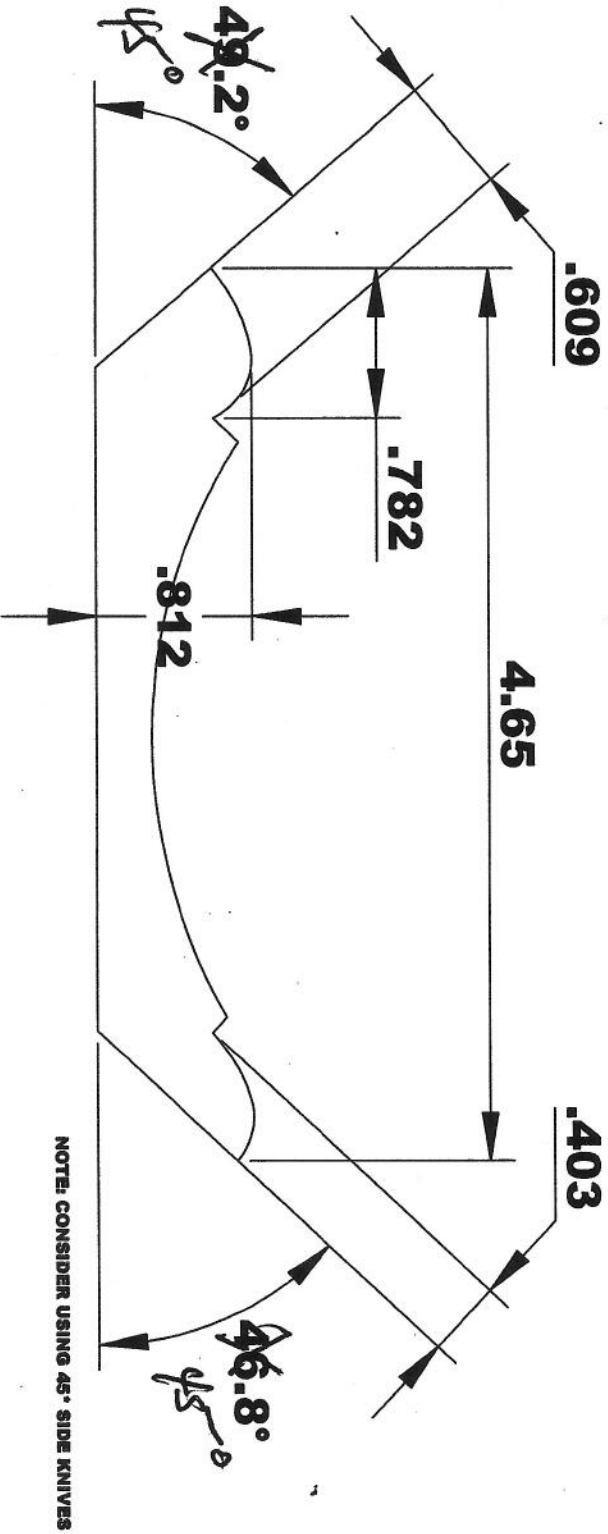

INSIDE OF MACHINE

OUTFEED VIEW COMING

# SPECIFICATIONS

MOULDING # **CR 26**

CUSTOMER: \_\_\_\_\_

COMMENTS: **20 \* HOOK**

MOULDER: 5/16 T-REX CORR., 1.5 START DEPTH, 10MM AXIALS

T-REX LONG WEAR

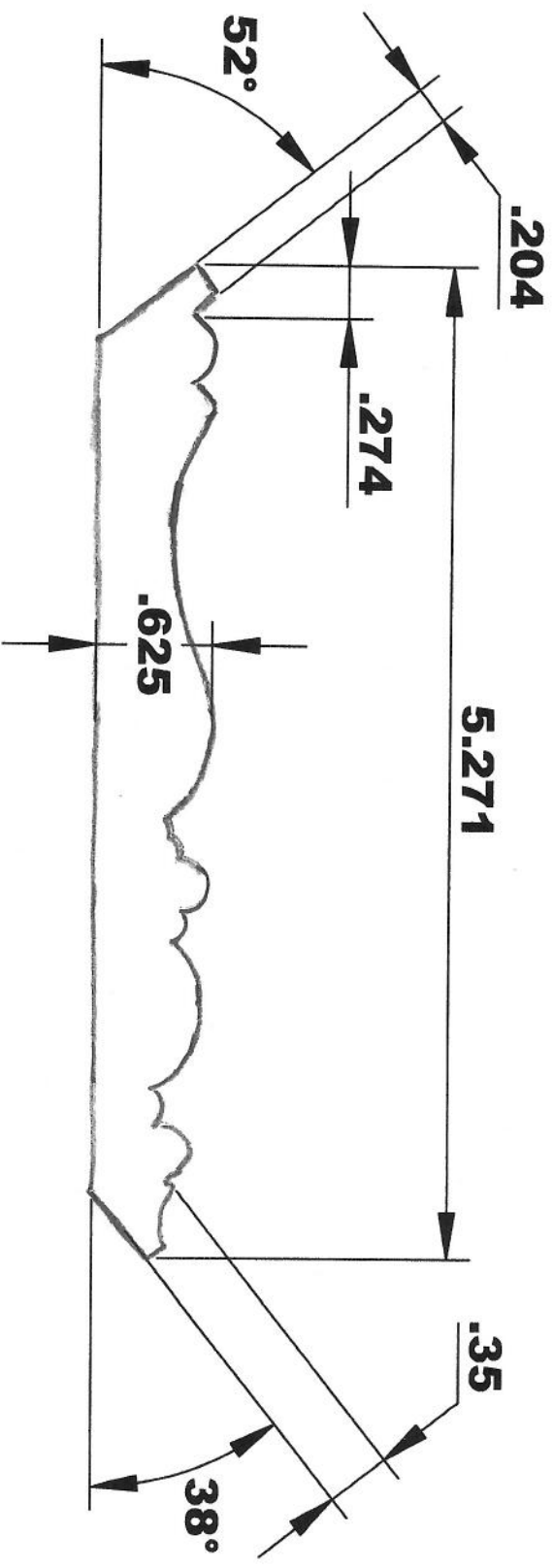

OUTFEED VIEW COMING

INSIDE OF MACHINE

# SPECIFICATIONS

MOULDING # CR 27

CUSTOMER: \_\_\_\_\_

COMMENTS: 20\* HOOK

MOULDER: 5/16 T-REX CORR., 1.5 START DEPTH, 10MM AXIALS

T-REX LONG WEAR

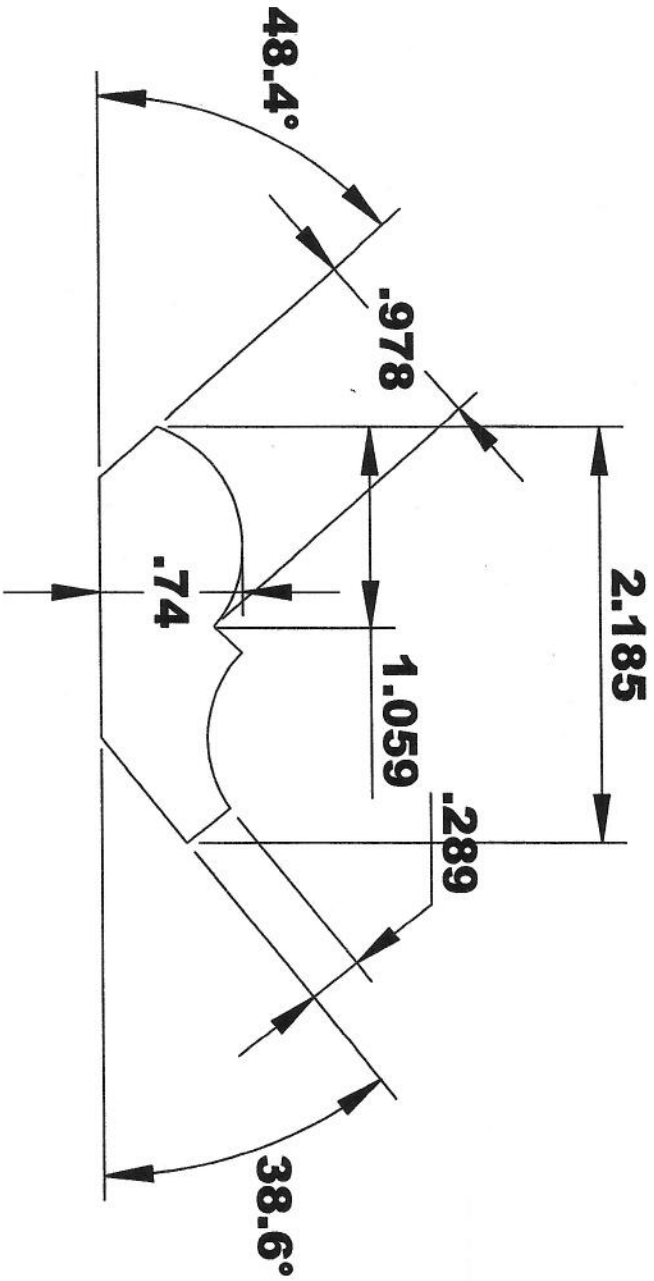

INSIDE OF MACHINE

OUTFEED VIEW COMING

# SPECIFICATIONS

MOULDING # **CR 28**

CUSTOMER: \_\_\_\_\_

COMMENTS: **20\* HOOK**

MOULDER: 5/16 T-REX CORR., 1.5 START DEPTH, 10MM AXIALS  
T-REX LONG WEAR

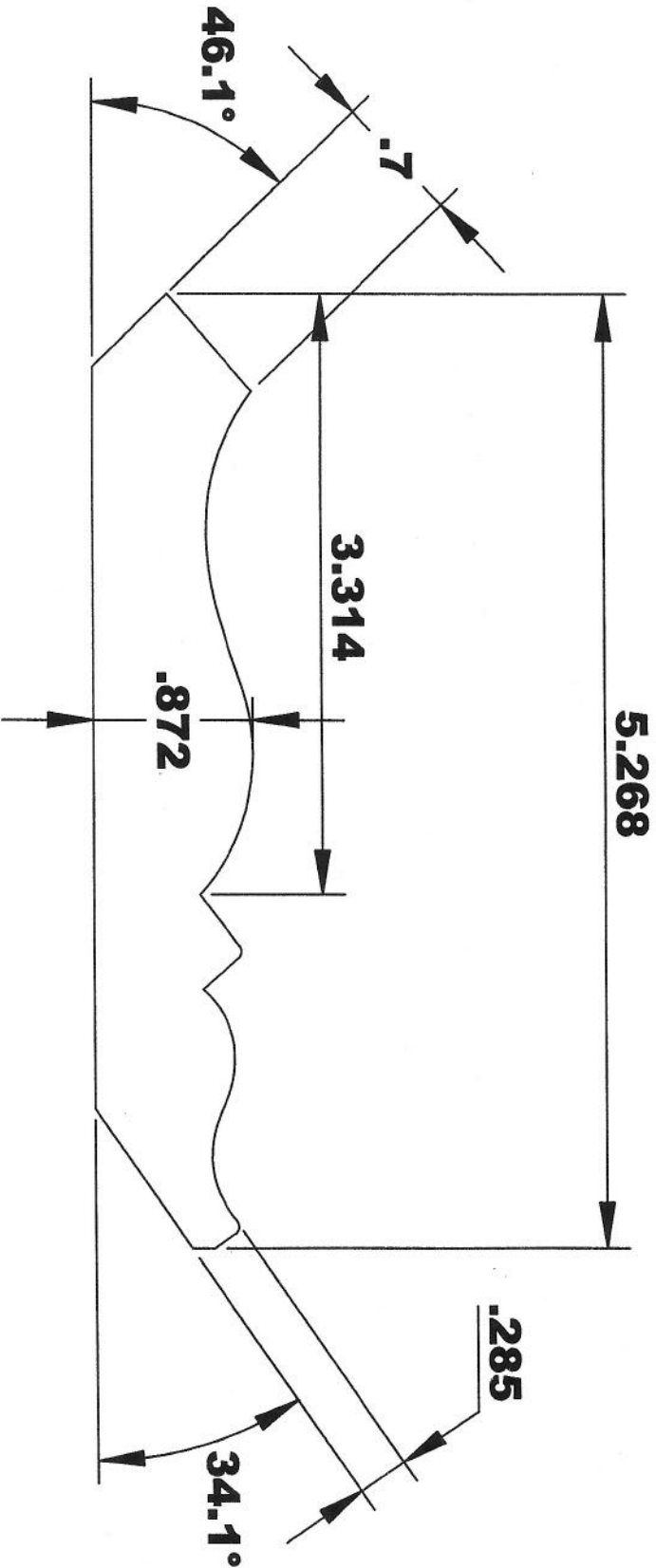

INSIDE OF MACHINE

OUTFEED VIEW COMING

# SPECIFICATIONS

MOULDING # CR 29

CUSTOMER: \_\_\_\_\_

COMMENTS: 20° HOOK

MOULDER: 5/16 T-REX CORR., 1.5 START DEPTH, 10MM AXIALS  
T-REX LONG WEAR

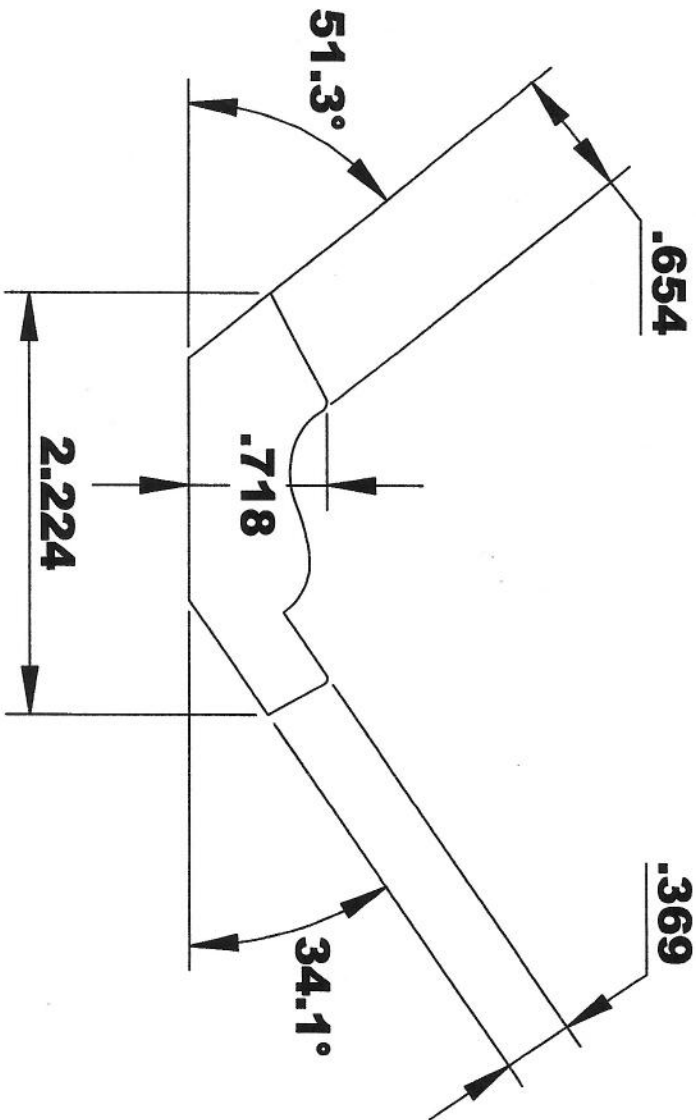

INSIDE OF MACHINE

OUTFEED VIEW COMING

# SPECIFICATIONS

MOULDING # CR 30

CUSTOMER: \_\_\_\_\_

COMMENTS: 20\* HOOK

MOULDER: 5/16 T-REX CORR., 1.5 START DEPTH, 10MM AXIALS  
T-REX LONG WEAR

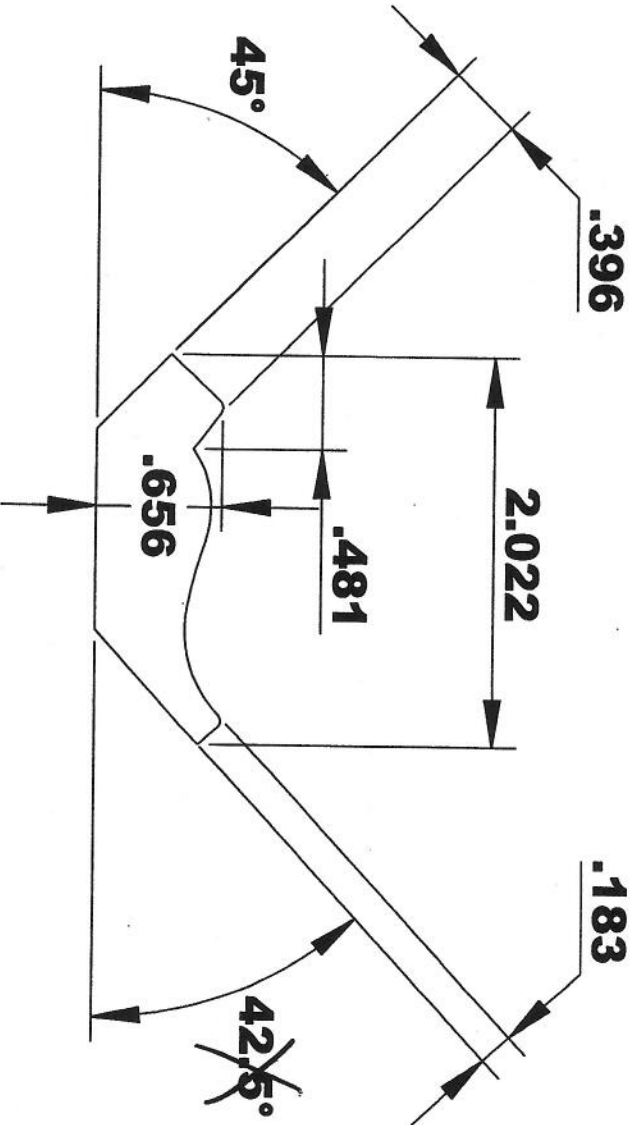

INSIDE OF MACHINE

OUTFEED VIEW COMING



# SPECIFICATIONS

MOULDING # CR 31

CUSTOMER: \_\_\_\_\_

COMMENTS: 20\* HOOK

MOULDER: 5/16 T-REX CORR., 1.5 START DEPTH, 10MM AXIALS

T-REX LONG WEAR

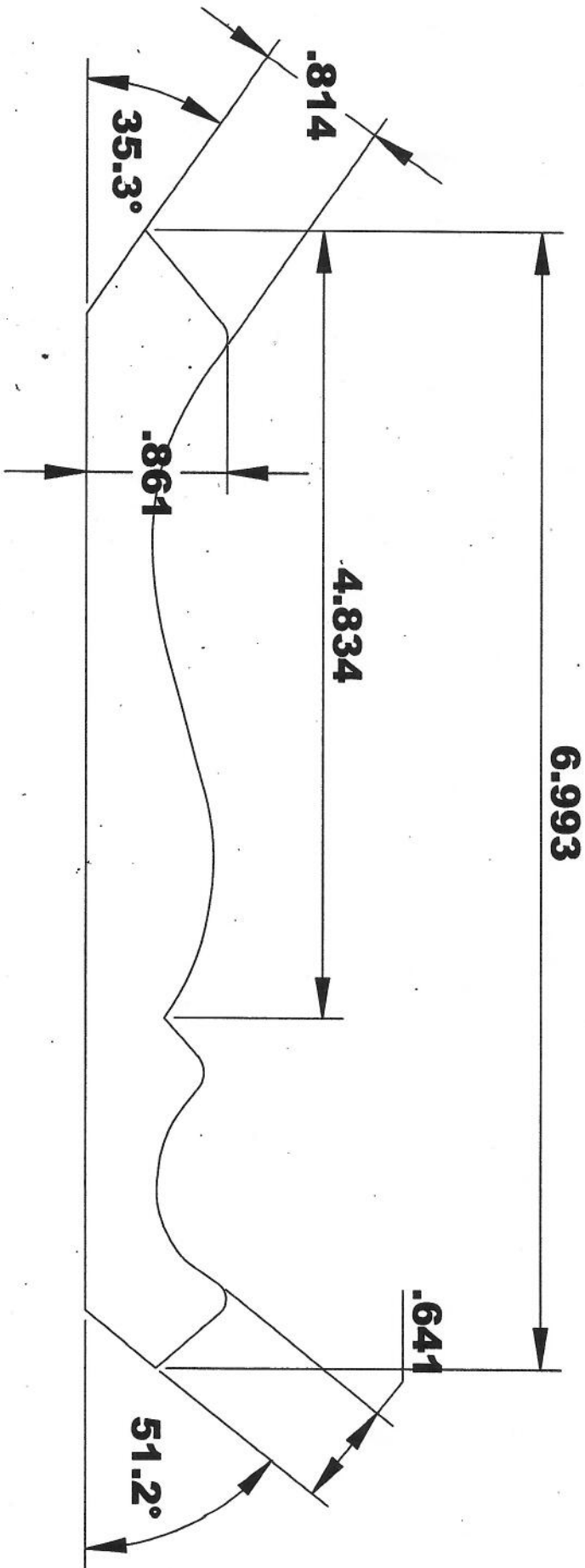

INSIDE OF MACHINE

OUTFEED VIEW COMING

# SPECIFICATIONS

MOULDING # CR 32

CUSTOMER: \_\_\_\_\_

COMMENTS: 20\* HOOK

MOULDER: 5/16 T-REX CORR., 1.5 START DEPTH, 10MM AXIALS  
T-REX LONG WEAR

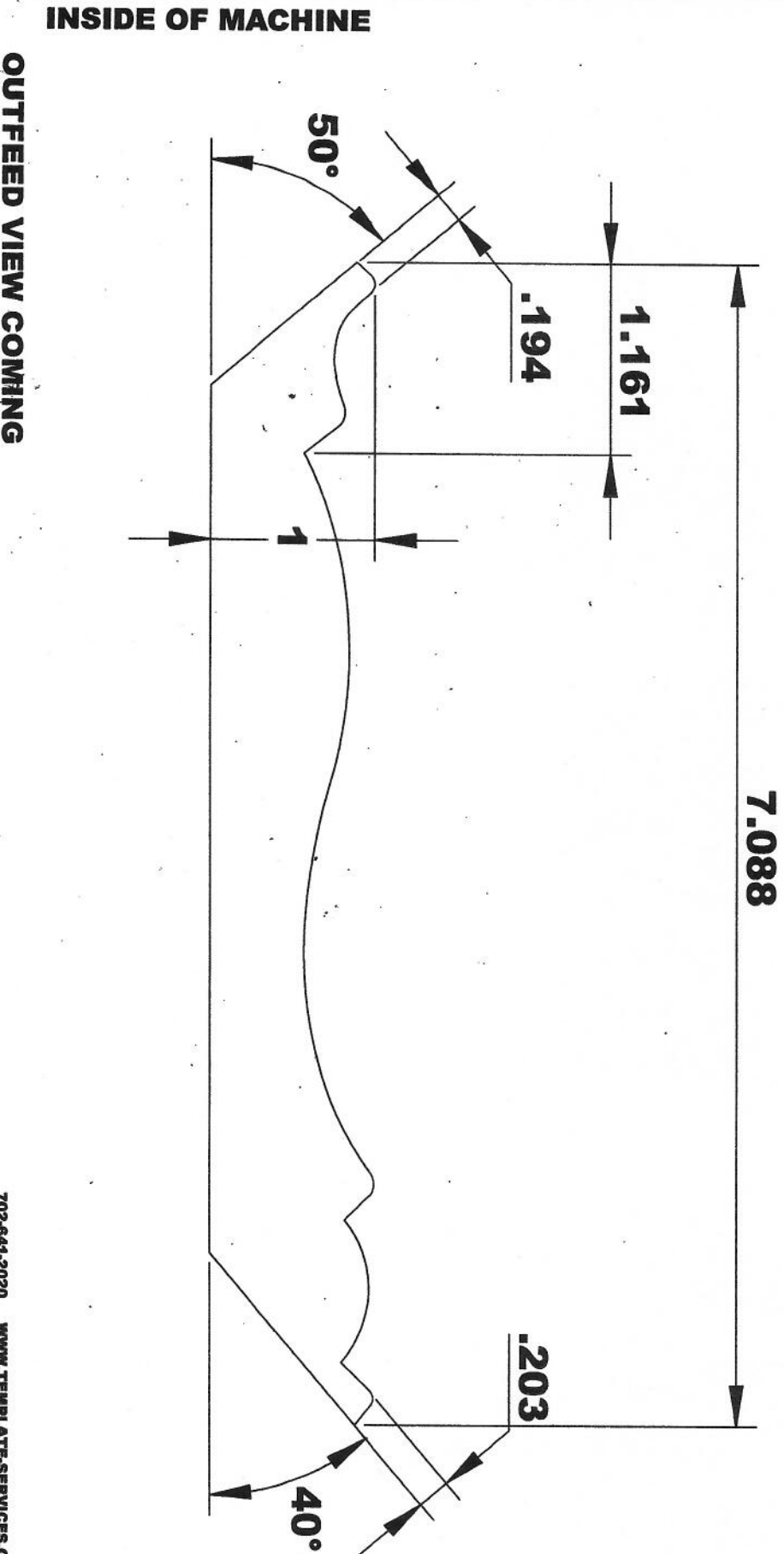

# SPECIFICATIONS

MOULDING # **CR 33**

CUSTOMER: \_\_\_\_\_

COMMENTS: **20\* HOOK**

MOULDER: 5/16 T-REX CORR., 1.5 START DEPTH, 10MM AXIALS  
T-REX LONG WEAR

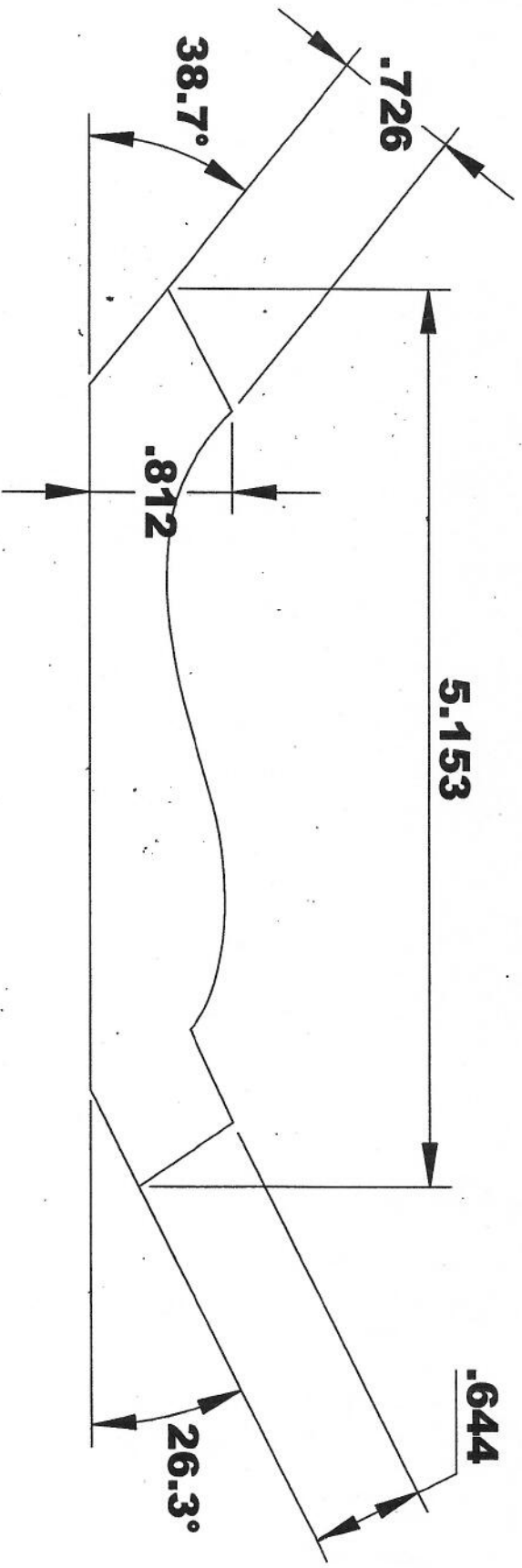

INSIDE OF MACHINE

OUTFEED VIEW COMING

# SPECIFICATIONS

MOULDING # CR 34

CUSTOMER: \_\_\_\_\_

COMMENTS: 20° HOOK

MOULDER: 5/16 T-REX CORR., 1.5 START DEPTH, 10MM AXIALS  
T-REX LONG WEAR

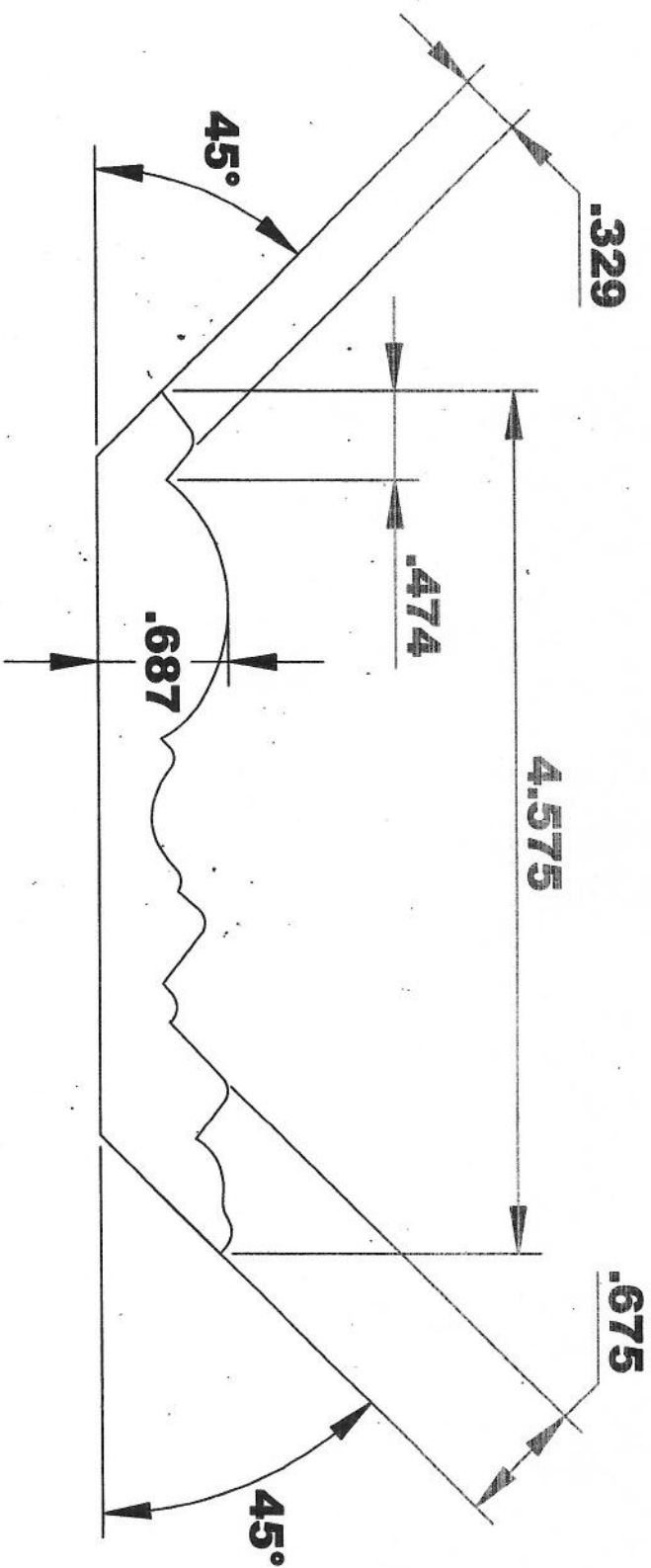

INSIDE OF MACHINE

OUTFEED VIEW COMING

# SPECIFICATIONS

MOULDING # **CR 35**

CUSTOMER: \_\_\_\_\_

COMMENTS: **20 \* HOOK**

MOULDER: 5/16 T-REX CORR., 1.5 START DEPTH, 10MM AXIALS  
T-REX LONG WEAR

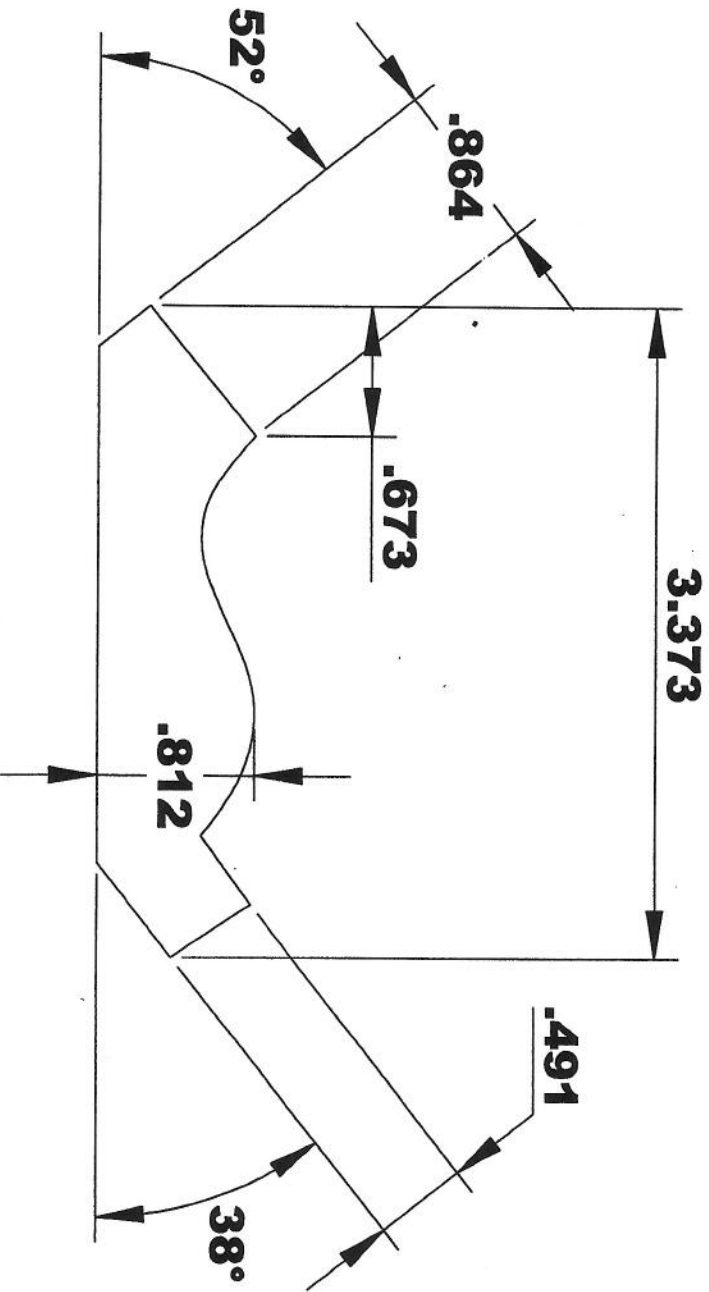

INSIDE OF MACHINE

OUTFEED VIEW COMING

# SPECIFICATIONS

MOULDING # CR 36

CUSTOMER: \_\_\_\_\_

COMMENTS: 20° HOOK

MOULDER: 5/16 T-REX CORR., 1.5 START DEPTH, 10MM AXIALS  
T-REX LONG WEAR

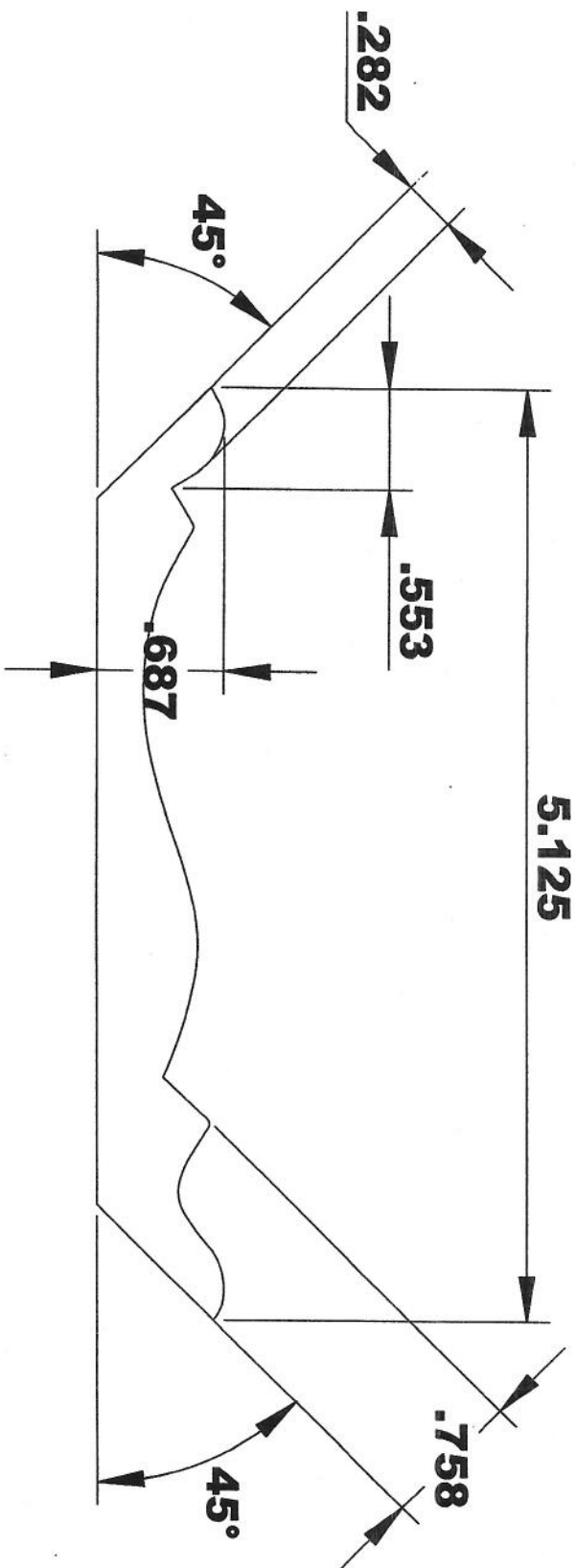

INSIDE OF MACHINE

OUTFEED VIEW COMING

# SPECIFICATIONS

MOULDING # CR 38

CUSTOMER: \_\_\_\_\_

COMMENTS: 20\* HOOK

MOULDER: 5/16 T-REX CORR., 1.5 START DEPTH, 10MM AXIALS

T-REX LONG WEAR

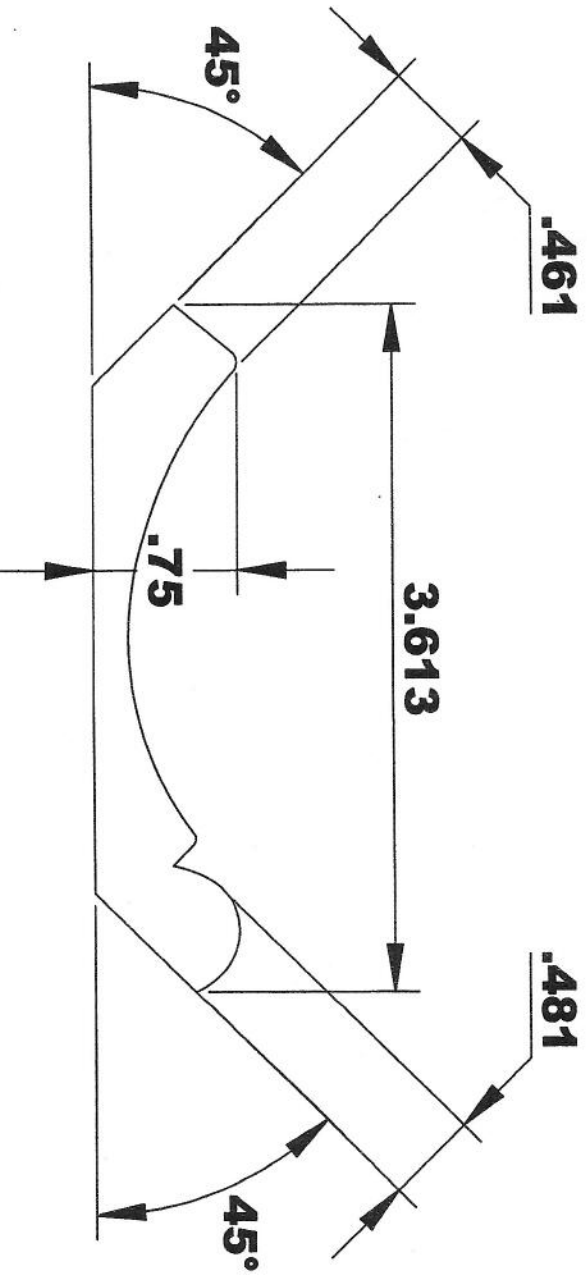

INSIDE OF MACHINE

OUTFEED VIEW COMING

# SPECIFICATIONS

MOULDING # **CR 39**

CUSTOMER: \_\_\_\_\_

COMMENTS: **20 \* HOOK**

MOULDER: 5/16 T-REX CORR., 1.5 START DEPTH, 10MM AXIALS

T-REX LONG WEAR

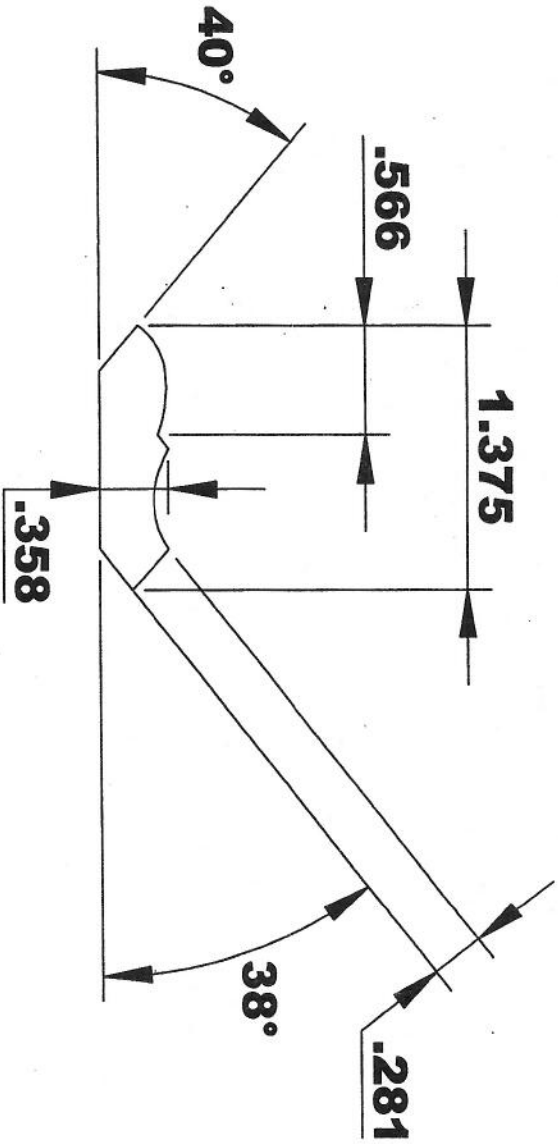

INSIDE OF MACHINE

OUTFEED VIEW COMING



# SPECIFICATIONS

MOULDING # CR 40

CUSTOMER: \_\_\_\_\_

COMMENTS: 20\* HOOK

MOULDER: 5/16 T-REX CORR., 1.5 START DEPTH, 10MM AXIALS  
T-REX LONG WEAR

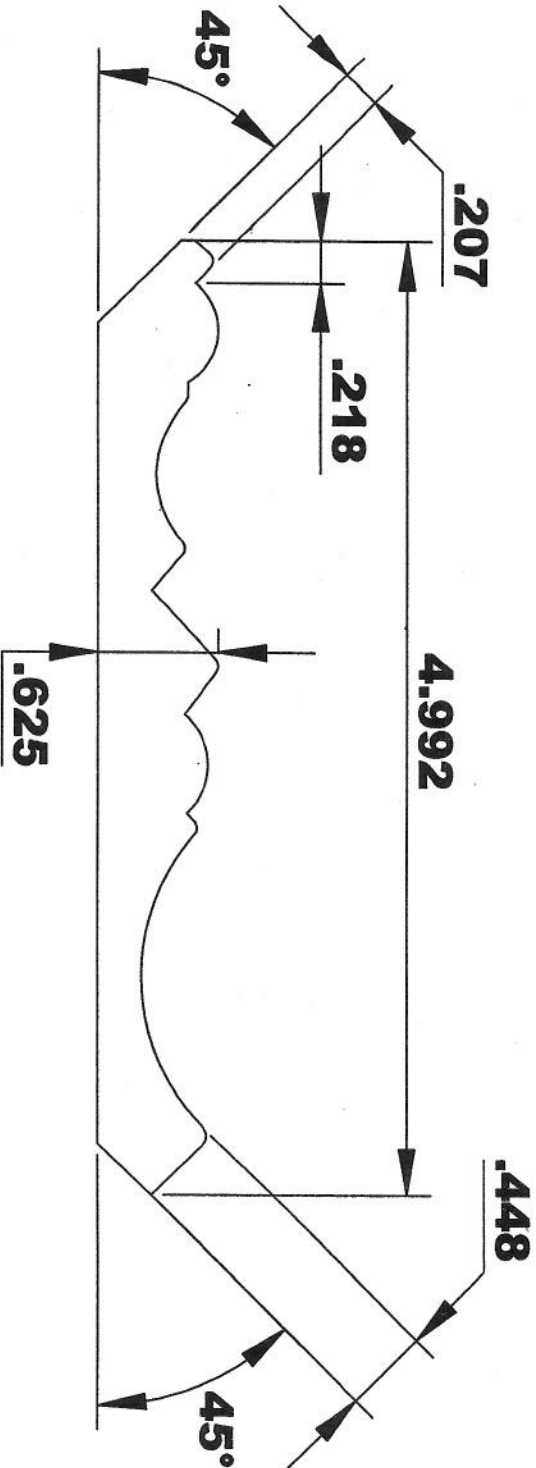

INSIDE OF MACHINE

OUTFEED VIEW COMING

# SPECIFICATIONS

MOULDING # CR 41

CUSTOMER: \_\_\_\_\_

COMMENTS: 20 \* HOOK

MOULDER: 5/16 T-REX CORR., 1.5 START DEPTH, 10MM AXIALS  
T-REX LONG WEAR

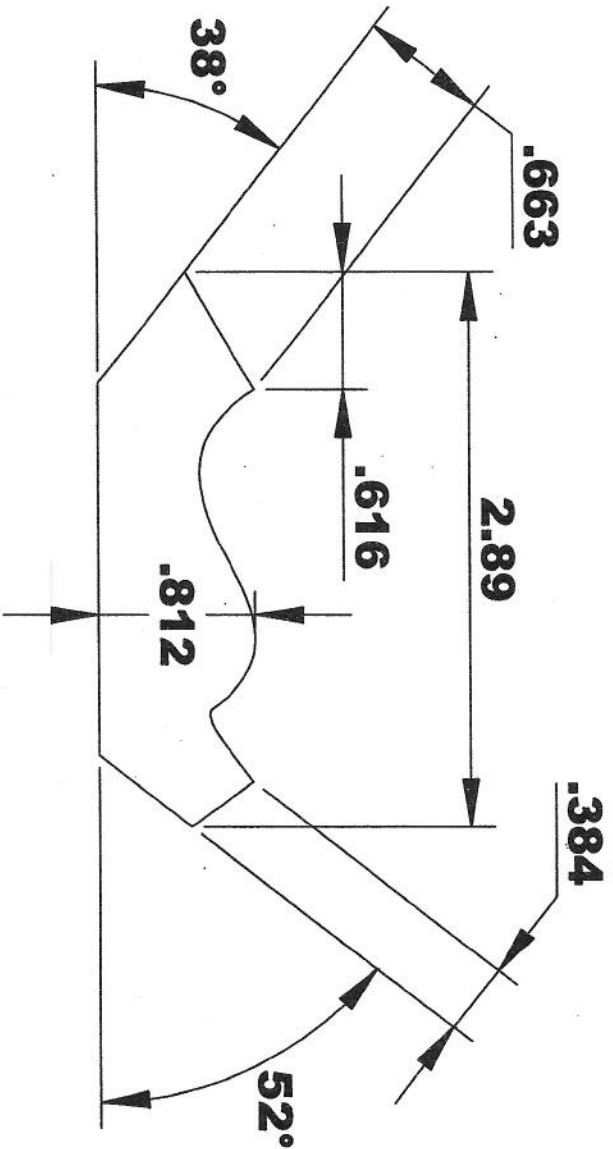

INSIDE OF MACHINE

OUTFEED VIEW COMING

# SPECIFICATIONS

MOULDING # CR 42

CUSTOMER: \_\_\_\_\_

COMMENTS: 20 \* HOOK

MOULDER: 5/16 T-REX CORR., 1.5 START DEPTH, 10MM AXIALS  
T-REX LONG WEAR

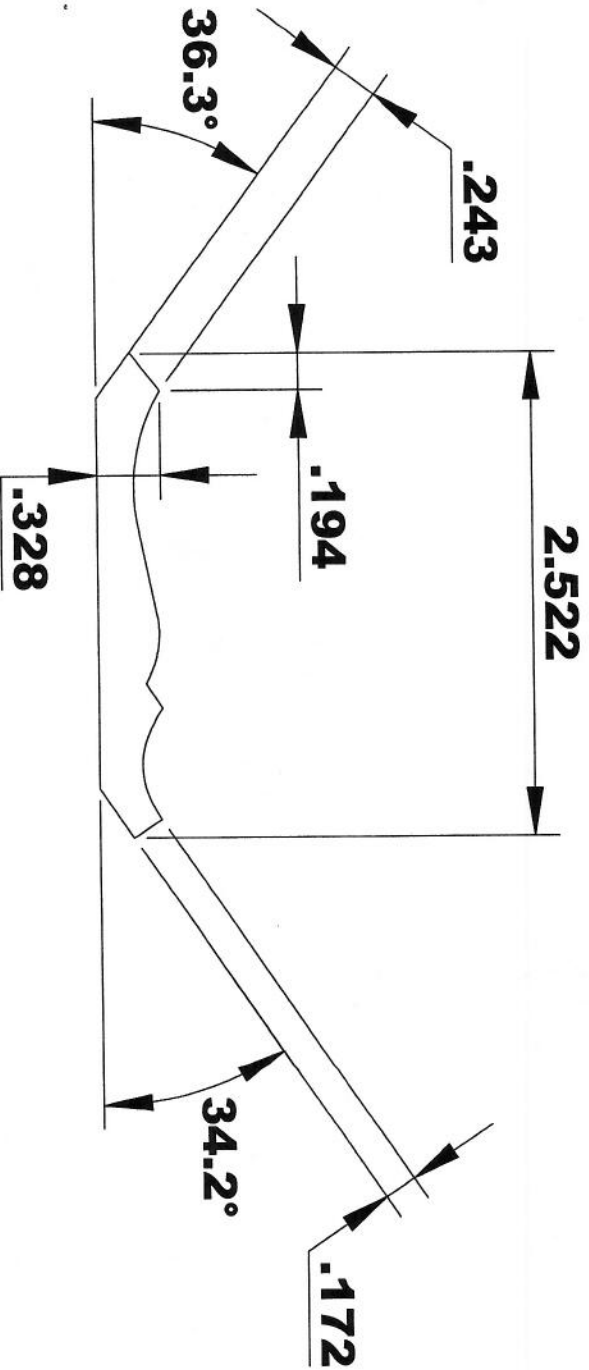

INSIDE OF MACHINE

OUTFEED VIEW COMING

# SPECIFICATIONS

MOULDING # CR 43

CUSTOMER: \_\_\_\_\_

COMMENTS: 20 \* HOOK

MOULDER: 5/16 T-REX CORR., 1.5 START DEPTH, 10MM AXIALS

T-REX LONG WEAR

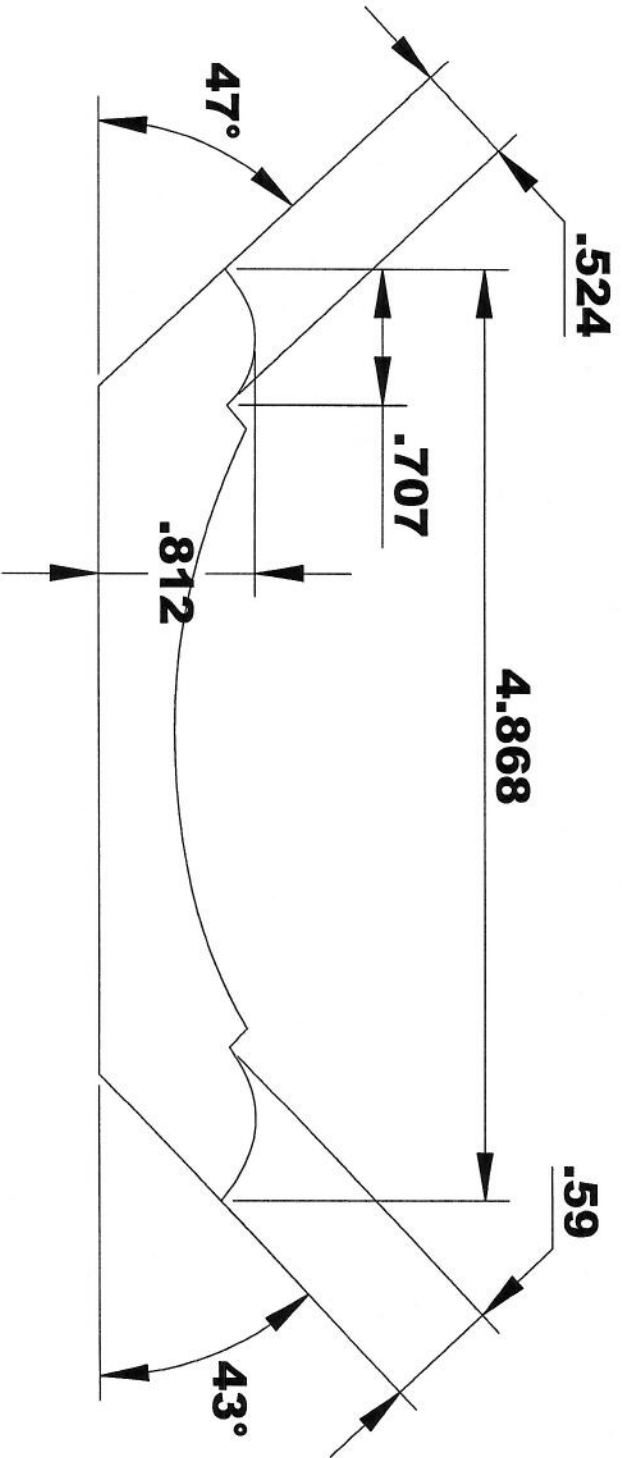

NOTE: NOT SYMMETRICAL

INSIDE OF MACHINE

OUTFEED VIEW COMING

# SPECIFICATIONS

MOULDING # **CR 44**

CUSTOMER: \_\_\_\_\_

COMMENTS: **20\* HOOK**

MOULDER: 5/16 T-REX CORR., 1.5 START DEPTH, 10MM AXIALS

T-REX LONG WEAR

REVERSE ENG. MULT. ( 0.9569 ) FROM KNIFE TO TEMPLATE

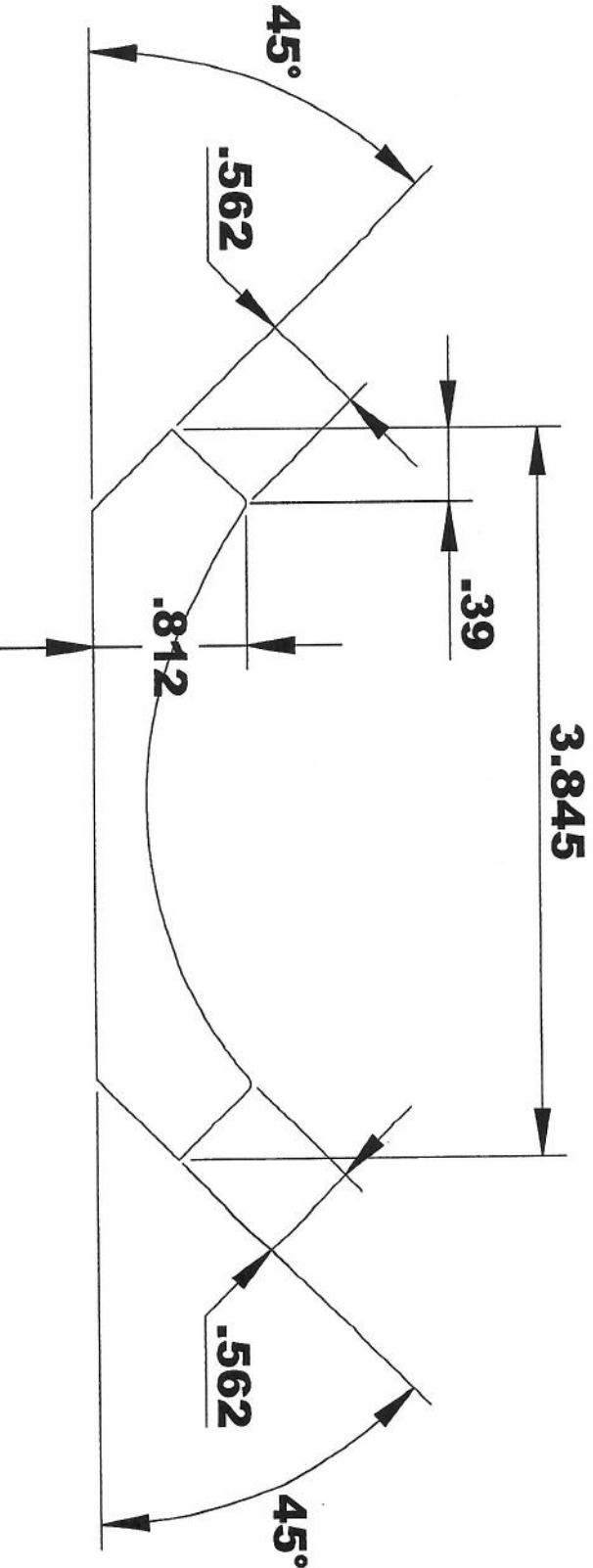
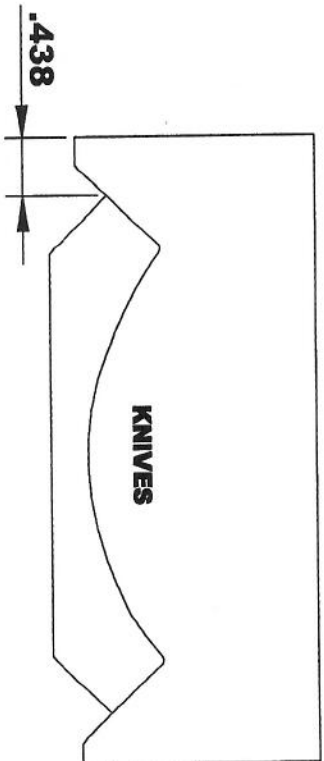

NOTE: CONCEPTUAL DRAWING ONLY, PAST RUNS MAY VARY

INSIDE OF MACHINE

OUTFEED VIEW COMING

# SPECIFICATIONS

MOULDING # CR 45

CUSTOMER: \_\_\_\_\_

COMMENTS: 20 \* HOOK

MOULDER: 5/16 T-REX CORR., 1.5 START DEPTH, 10MM AXIALS  
T-REX LONG WEAR

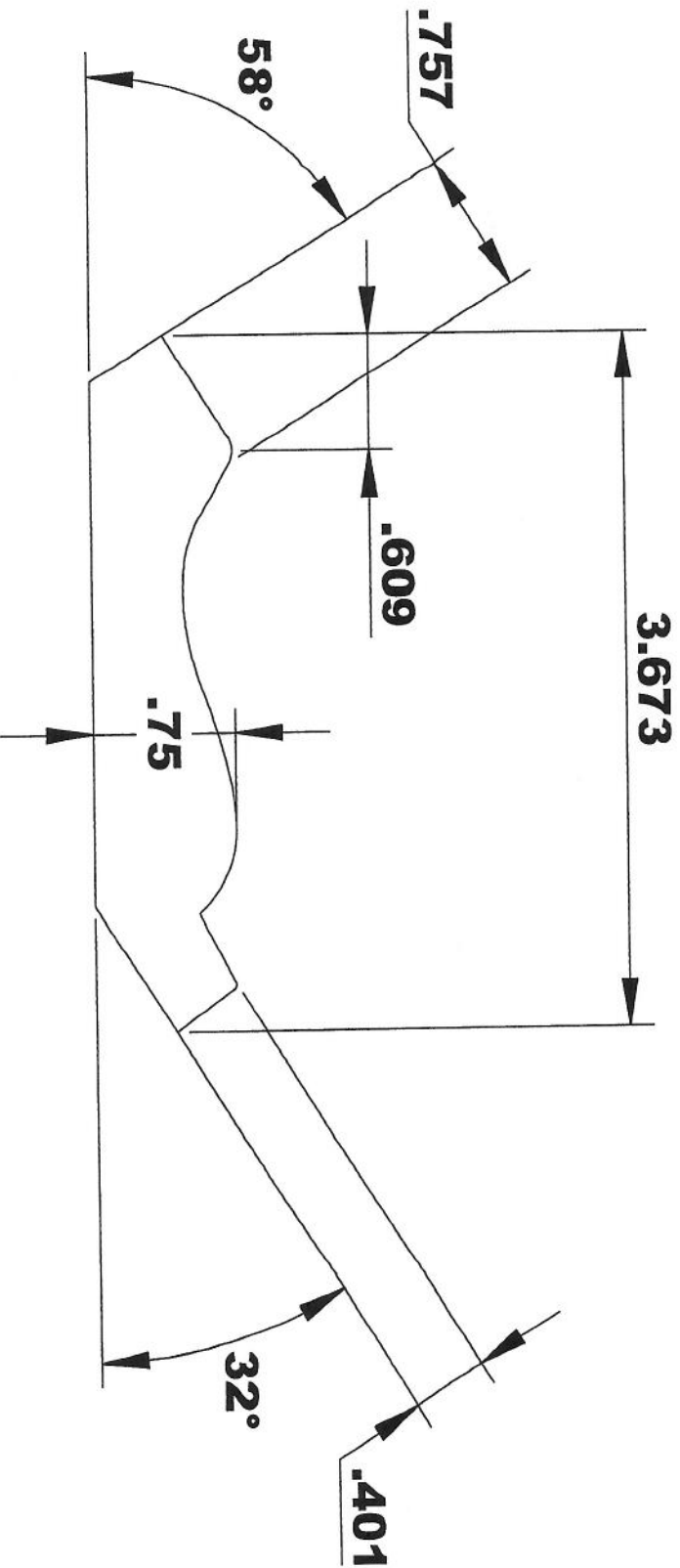

INSIDE OF MACHINE

OUTFEED VIEW COMING

# SPECIFICATIONS

MOULDING # **CR 46**

CUSTOMER: \_\_\_\_\_

COMMENTS: **20 \* HOOK**

MOULDER: 5/16 T-REX CORR., 1.5 START DEPTH, 10MM AXIALS

T-REX LONG WEAR

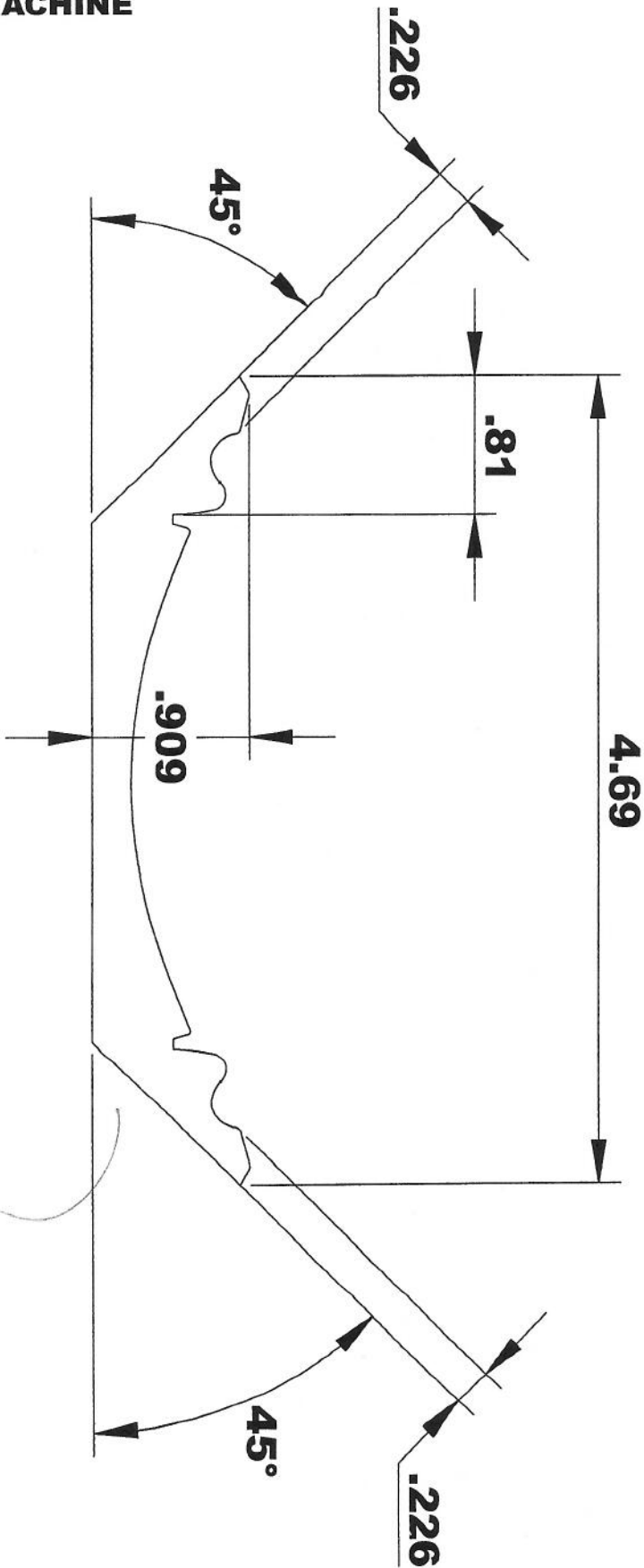

NOTE: MAKE SYMMETRICAL

INSIDE OF MACHINE

OUTFEED VIEW COMING

# SPECIFICATIONS

MOULDING # CR 47

CUSTOMER: \_\_\_\_\_

COMMENTS: 20\* HOOK

MOULDER: 5/16 T-REX CORR., 1.5 START DEPTH, 10MM AXIALS  
T-REX LONG WEAR

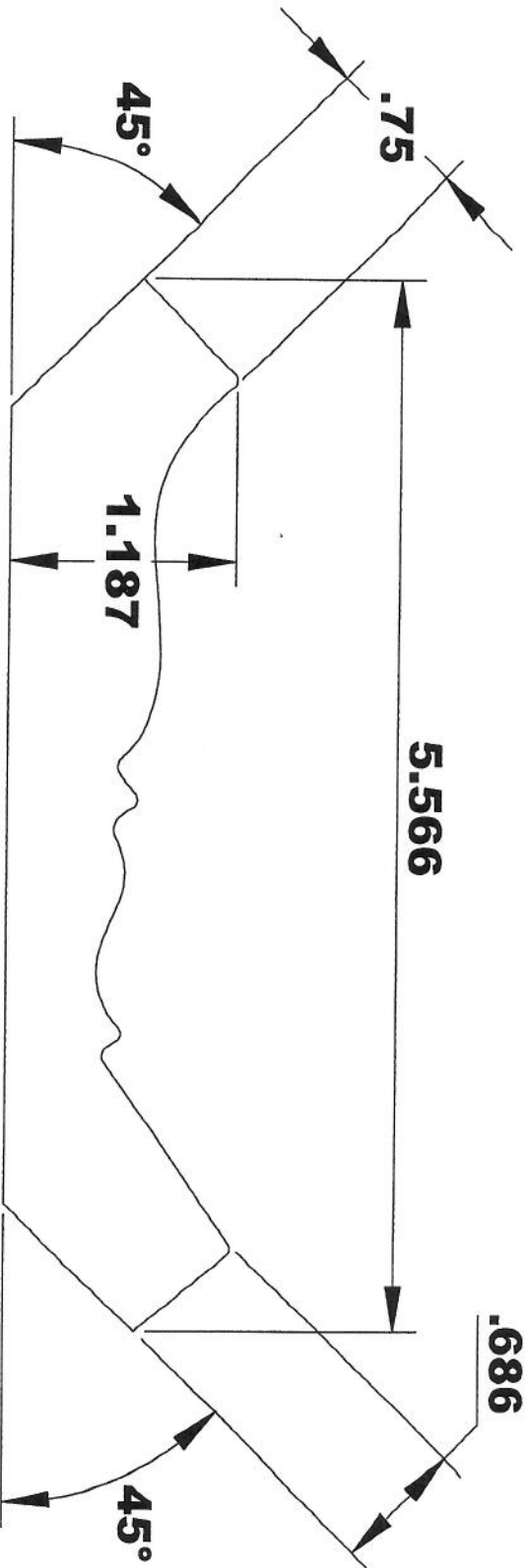

INSIDE OF MACHINE

OUTFEED VIEW COMING



# SPECIFICATIONS

MOULDING # **CR 48**

CUSTOMER: \_\_\_\_\_

COMMENTS: **20\* HOOK**

MOULDER: 5/16 T-REX CORR., 1.375 START DEPTH, 10MM AXIALS

T-REX LONG WEAR

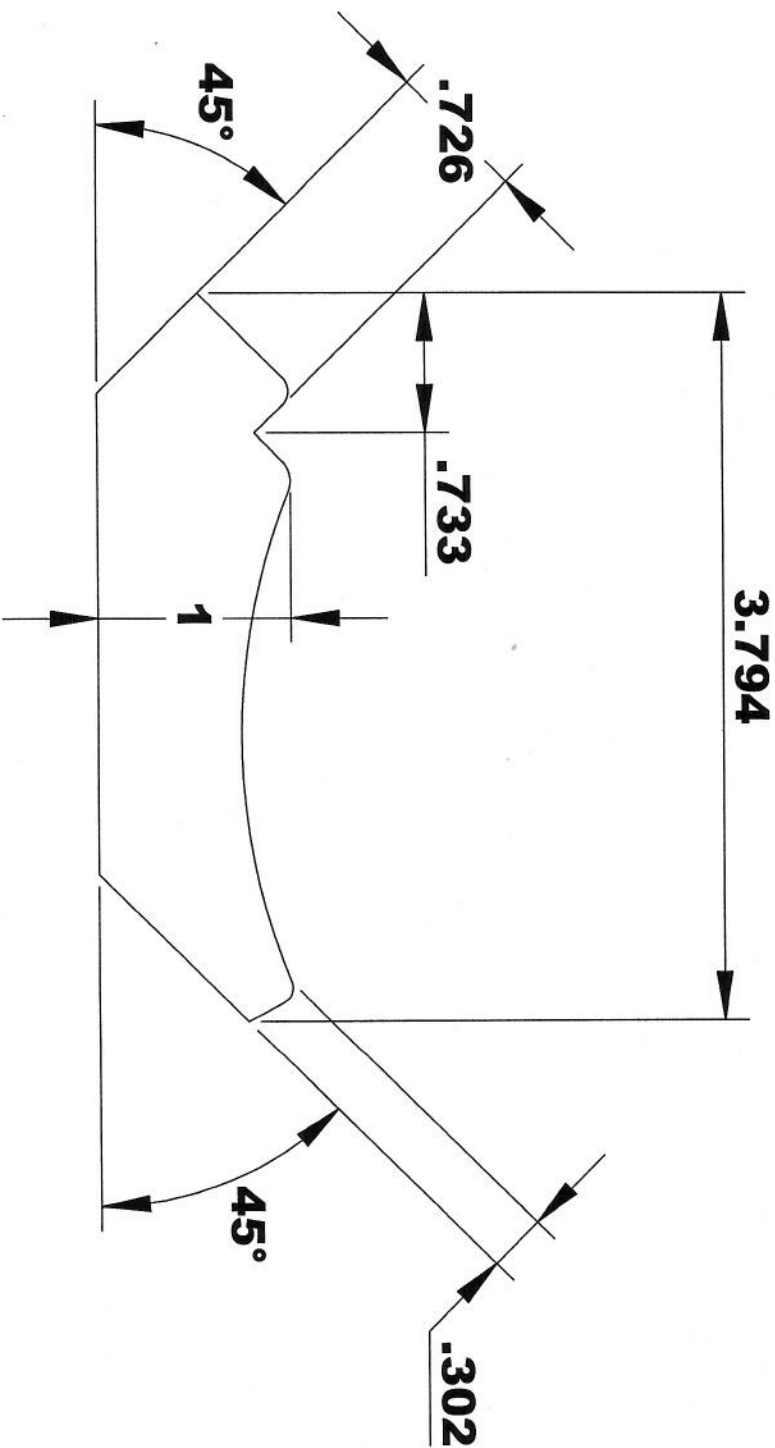

INSIDE OF MACHINE

OUTFEED VIEW COMING

# SPECIFICATIONS

MOULDING # **CR 49**

CUSTOMER: \_\_\_\_\_

COMMENTS: **20\* HOOK**

MOULDER: 5/16 T-REX CORR., 1.5 START DEPTH, 10MM AXIALS

T-REX LONG WEAR

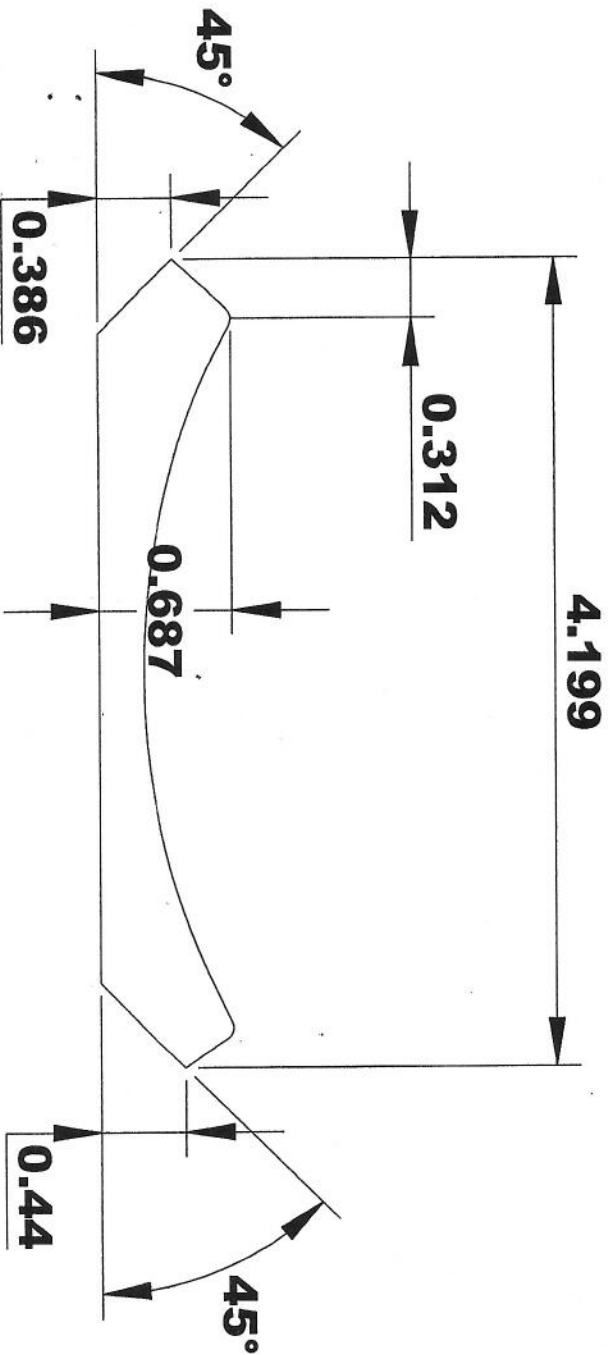

INSIDE OF MACHINE

OUTFEED VIEW COMING

# SPECIFICATIONS

MOULDING # CR 50

CUSTOMER: \_\_\_\_\_

COMMENTS: 20 \* HOOK

MOULDER: 5/16 T-REX CORR., 1.375 START DEPTH, 10MM AXIALS

T-REX LONG WEAR

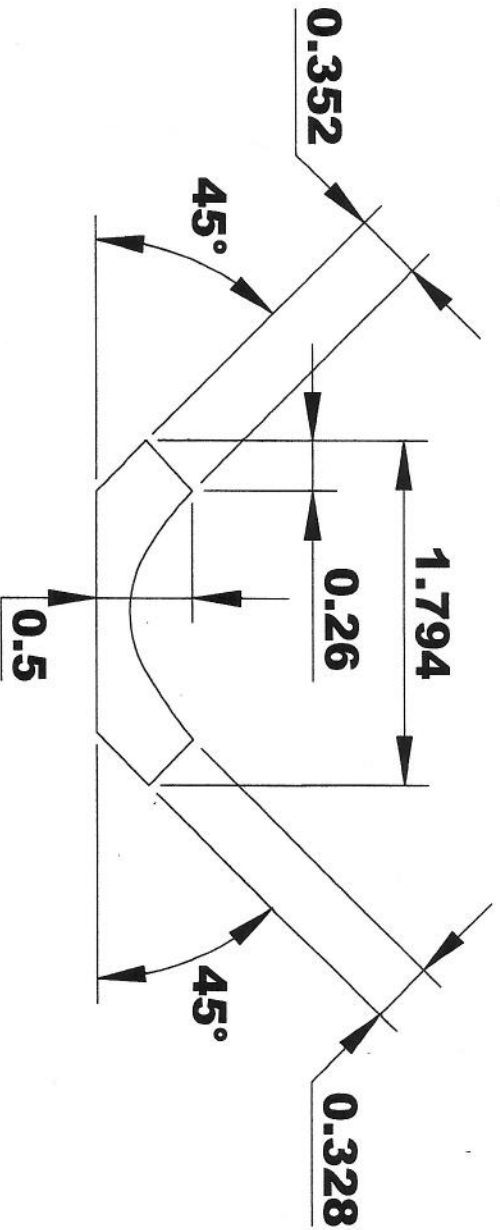

INSIDE OF MACHINE

OUTFEED VIEW COMING

# SPECIFICATIONS

MOULDING # **CR 51**

CUSTOMER: \_\_\_\_\_

COMMENTS: **20 \* HOOK**

MOULDER: 5/16 T-REX CORR., 1.375 START DEPTH, 10MM AXIALS  
T-REX LONG WEAR

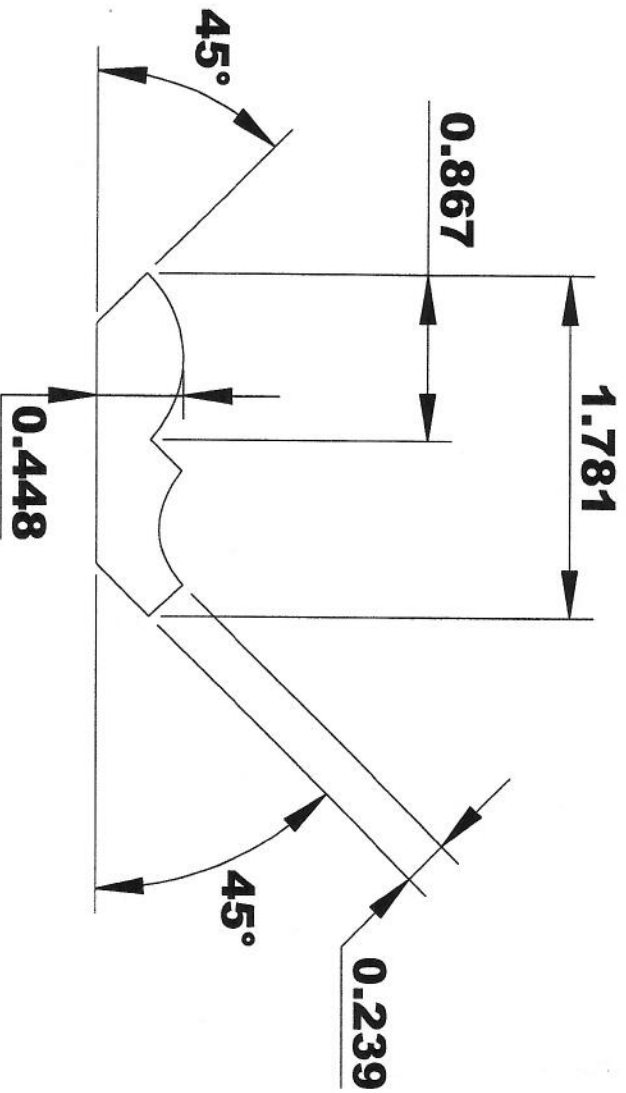

INSIDE OF MACHINE

OUTFEED VIEW COMING

# SPECIFICATIONS

MOULDING # **CR 52**

CUSTOMER: \_\_\_\_\_

COMMENTS: **20\* HOOK**

MOULDER: 5/16 T-REX CORR., 1.375 START DEPTH, 10MM AXIALS  
T-REX LONG WEAR

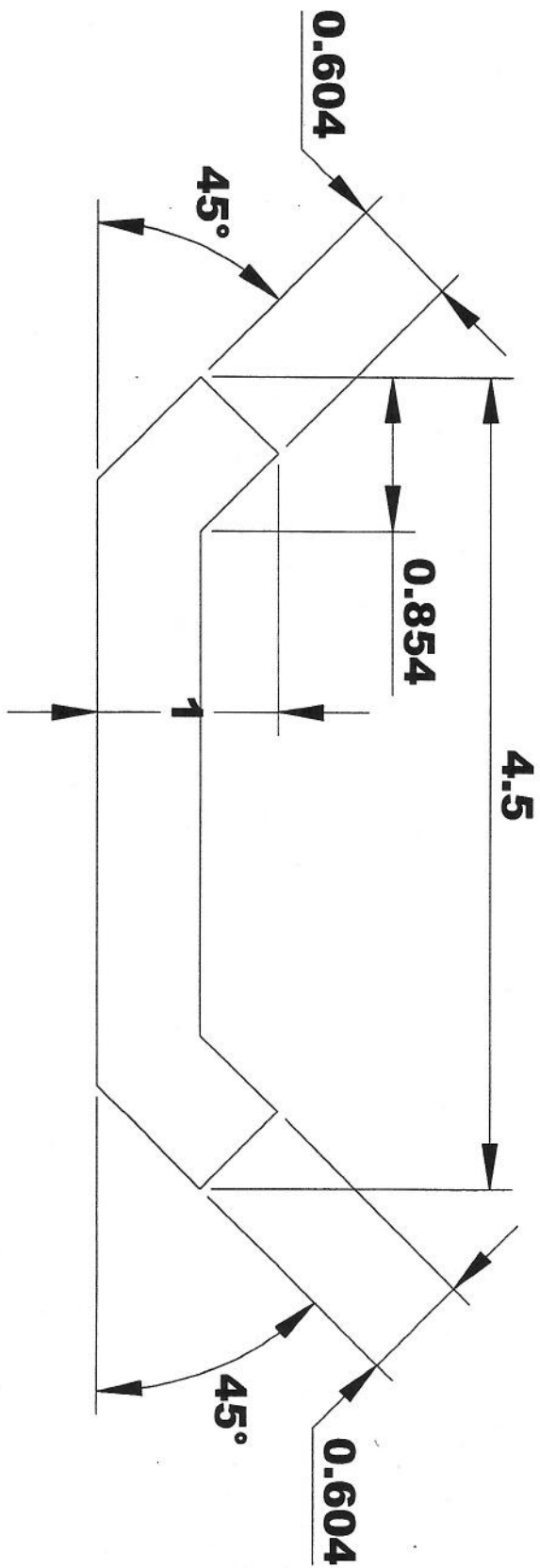

INSIDE OF MACHINE

OUTFEED VIEW COMING

# SPECIFICATIONS

MOULDING # **CR 53**

CUSTOMER: \_\_\_\_\_

COMMENTS: **20 \* HOOK**

MOULDER: 5/16 T-REX CORR., 1.375 START DEPTH, 10MM AXIALS

T-REX LONG WEAR

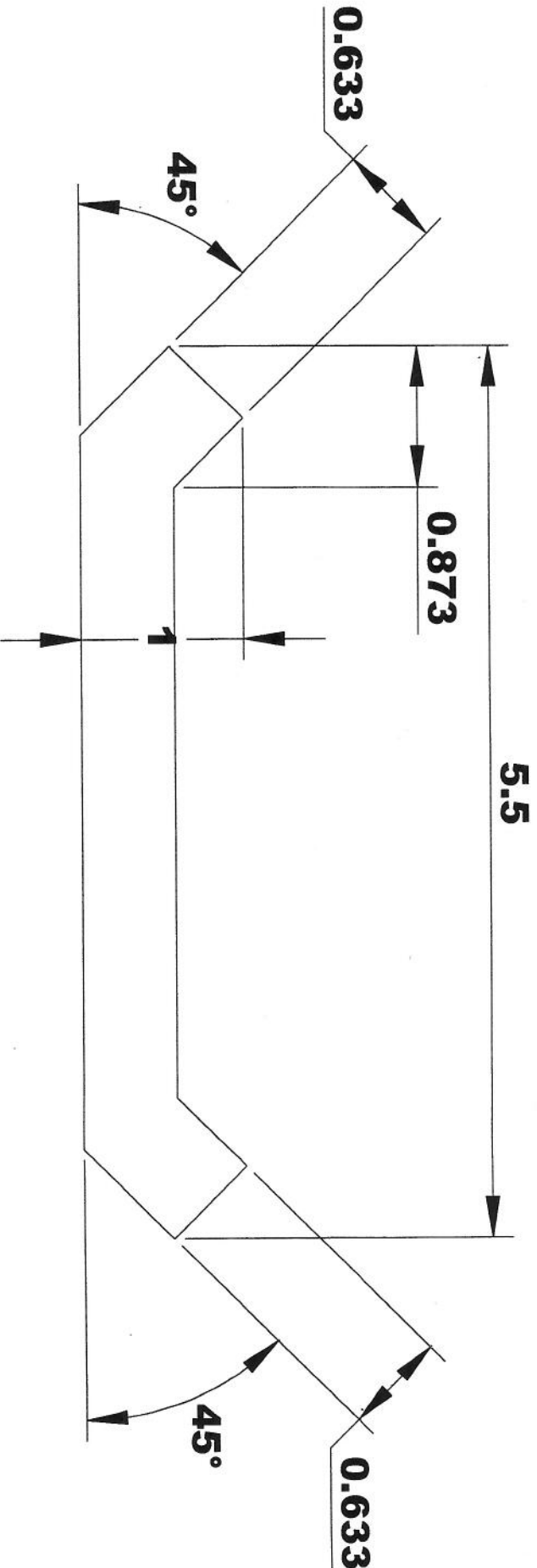

INSIDE OF MACHINE

OUTFEED VIEW COMING