

**Wes Vice Hardwoods
& Supply Inc.
Nederland, Texas**



**T&G and Siding
Mouldings**

SPECIFICATIONS

MOULDING # MC 1
CUSTOMER: _____
COMMENTS: 20* HOOK

Shaker Door Sticks

MOULDER: 5/16 T-REX CORR., 1.5 START DEPTH, 10MM AXIALS
T-REX LONG WEAR

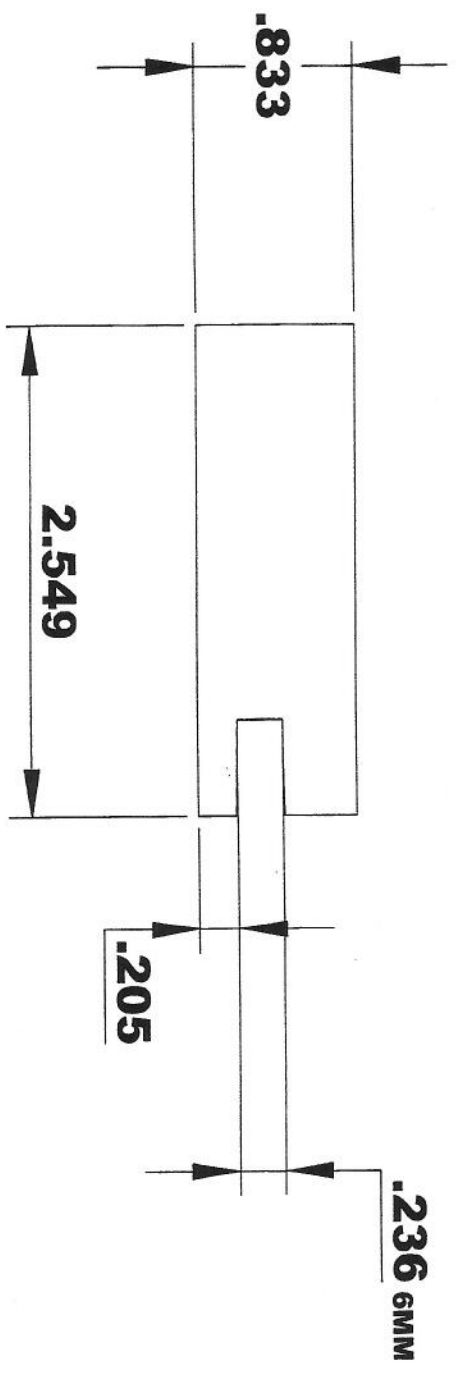

INSIDE OF MACHINE

OUTFEED VIEW COMING

SPECIFICATIONS

MOULDING # MC 2

CUSTOMER: _____

COMMENTS: 20* HOOK

MOULDER: 5/16 T-REX CORR., 1.5 START DEPTH, 10MM AXIALS
T-REX LONG WEAR

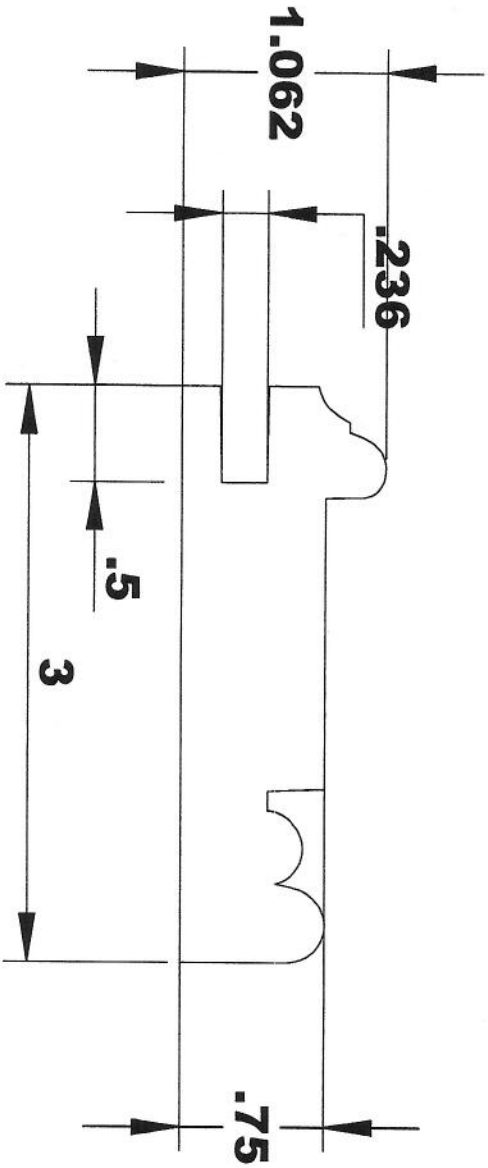

INSIDE OF MACHINE

OUTFEED VIEW COMING

SPECIFICATIONS

MOULDING # TG 1

CUSTOMER:

COMMENTS: 20* HOOK

MOULDER: 5/16 T-REX CORR., 1.5 START DEPTH, 10MM AXIALS
T-REX LONG WEAR

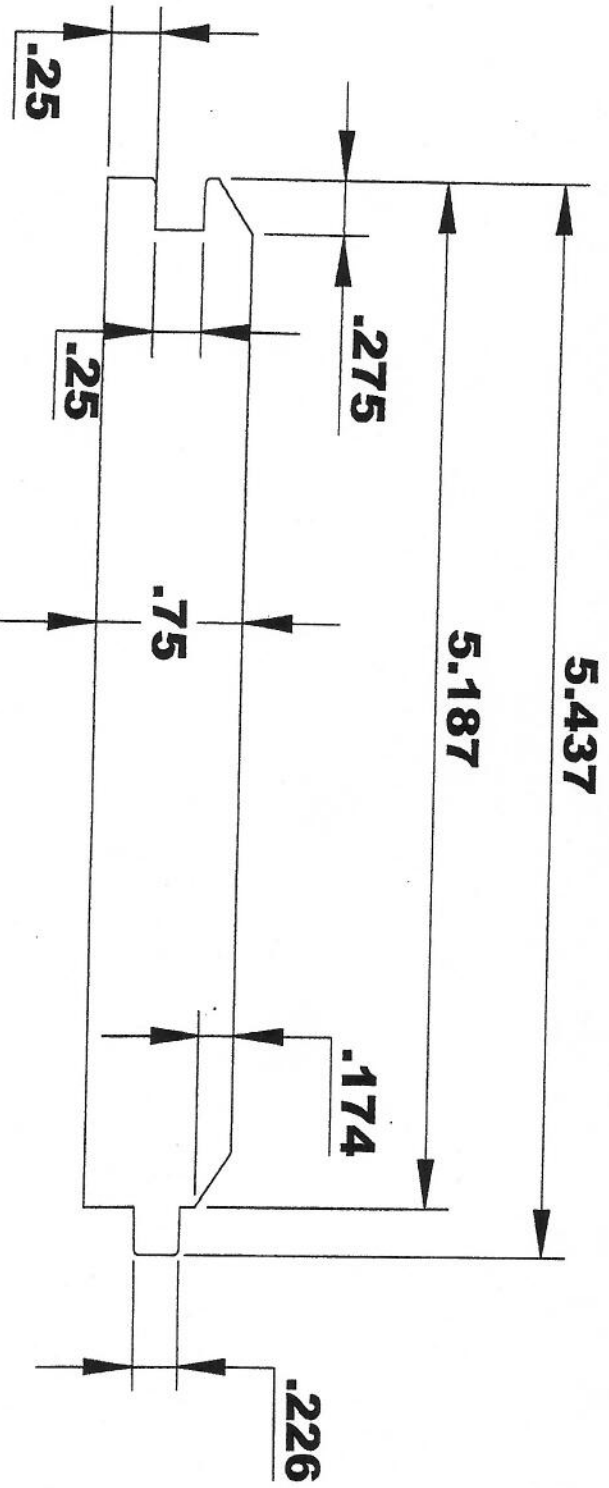
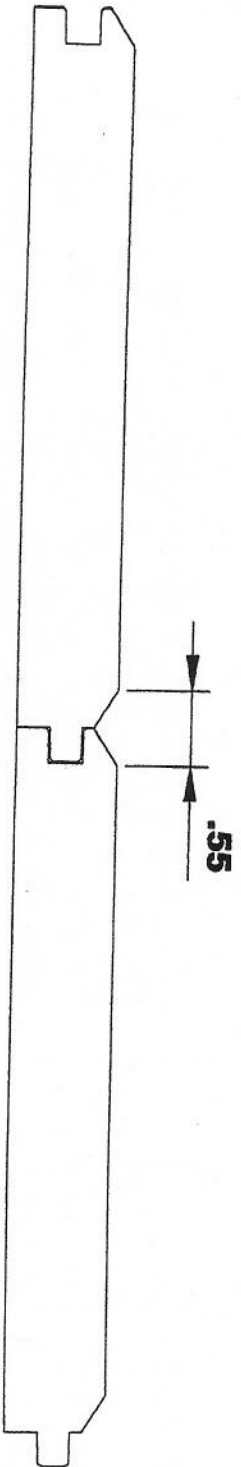

INSIDE OF MACHINE

OUTFEED VIEW COMING

SPECIFICATIONS

MOULDING # **TG 1**

CUSTOMER: **MIDDLE V**

COMMENTS: **20* HOOK**

MOULDER: 5/16 T-REX CORR., 1.5 START DEPTH, 10MM AXIALS
T-REX LONG WEAR

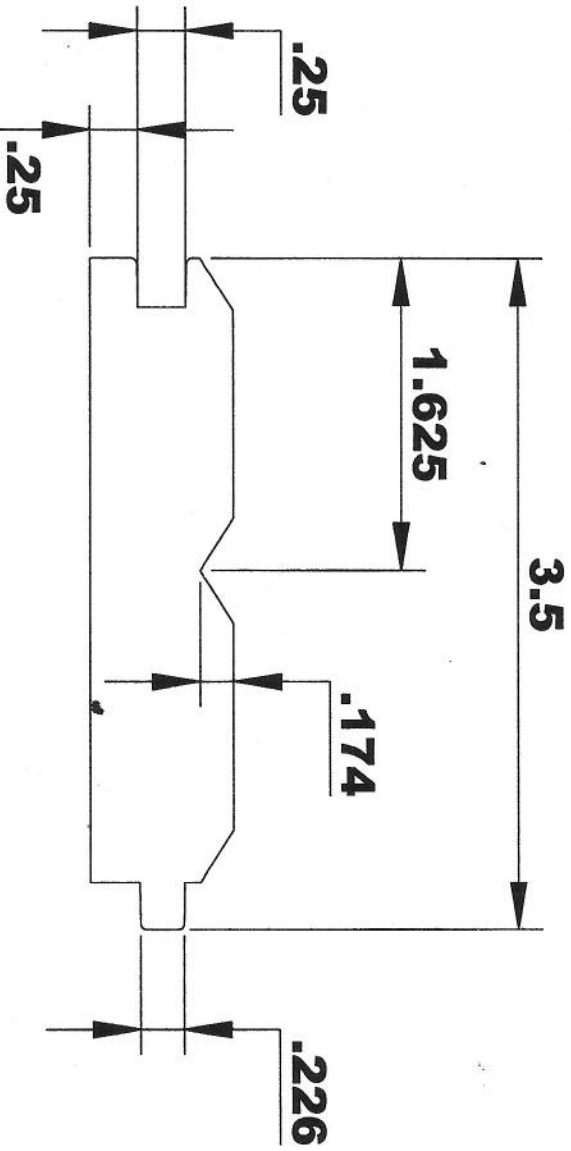
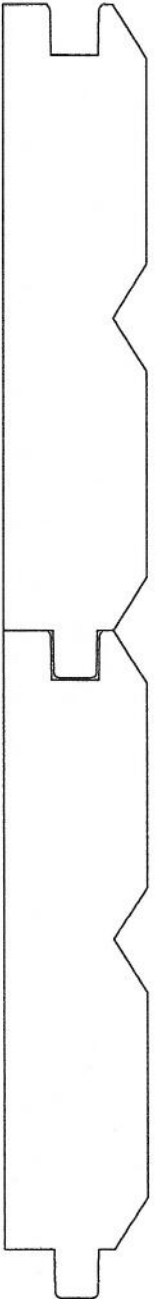

SPECIFICATIONS

MOULDING # **TG 2**

CUSTOMER: _____

COMMENTS: **20* HOOK**

MOULDER: 5/16 T-REX CORR., 1.5 START DEPTH, 10MM AXIALS

T-REX LONG WEAR

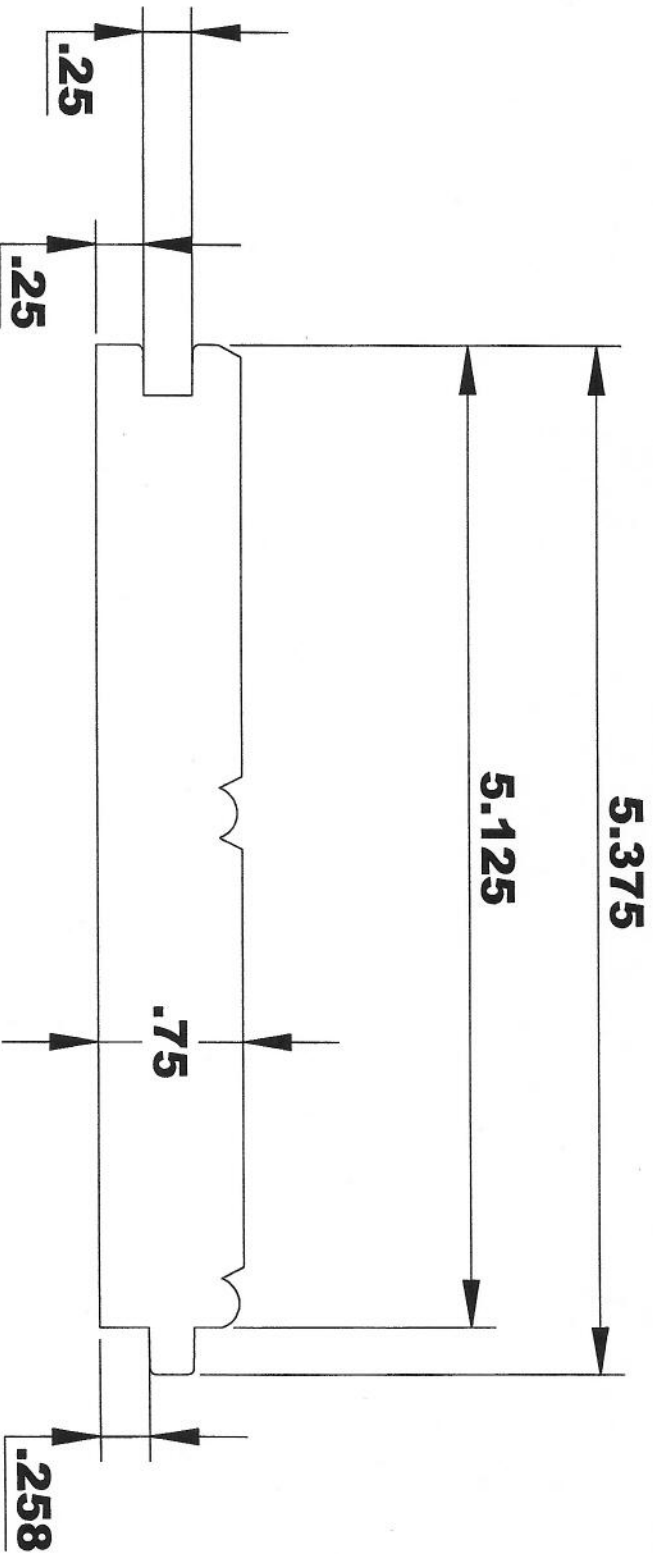
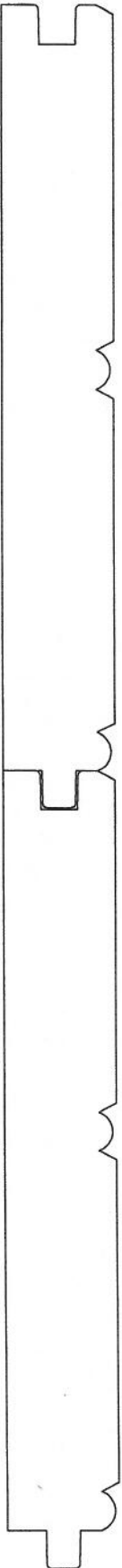

USE TS TG 4 SIDE KNIVES

INSIDE OF MACHINE

OUTFEED VIEW COMING

SPECIFICATIONS

MOULDING # **TS-TG 2**

CUSTOMER: **SNUG FIT**

COMMENTS: **20* HOOK**

Flooring

MOULDER: 5/16 T-REX CORR., 1.5 START DEPTH, 10MM AXIALS
T-REX LONG WEAR

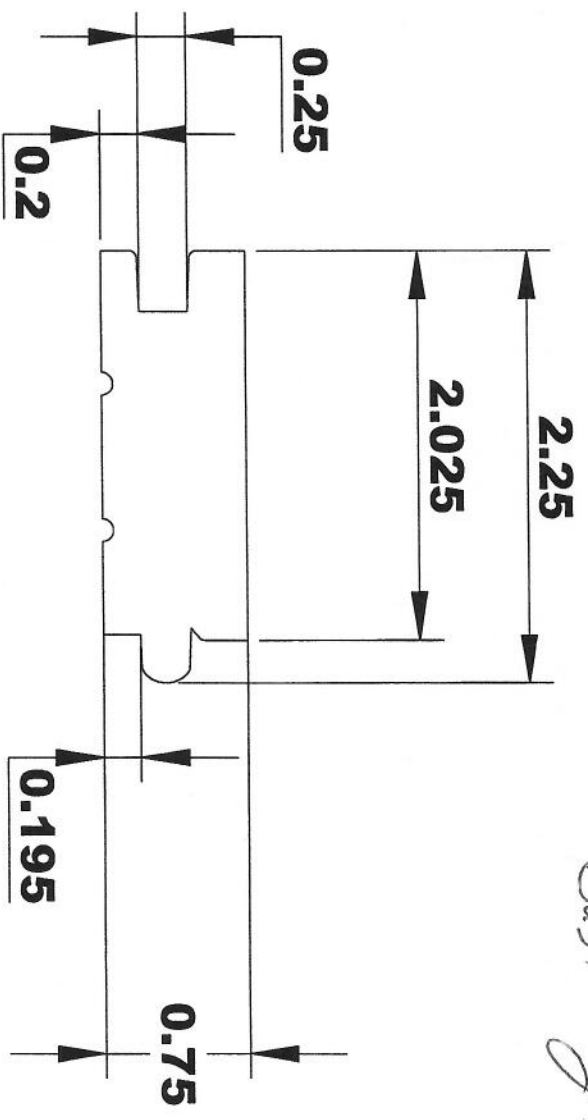
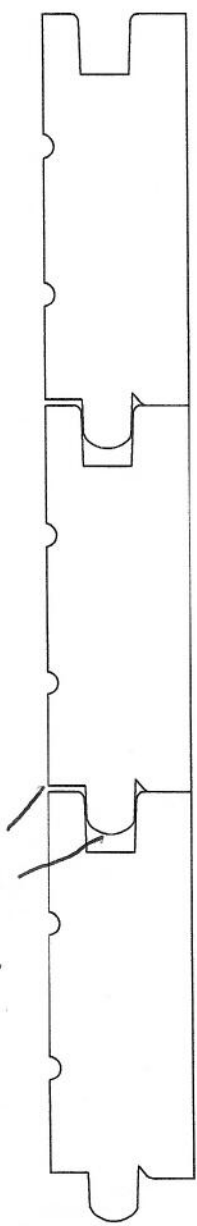

INSIDE OF MACHINE

OUTFEED VIEW COMING

SPECIFICATIONS

MOULDING # **TG 3**

CUSTOMER: _____

COMMENTS: **20 * HOOK**

MOULDER: 5/16 T-REX CORR., 1.5 START DEPTH, 10MM AXIALS

T-REX LONG WEAR

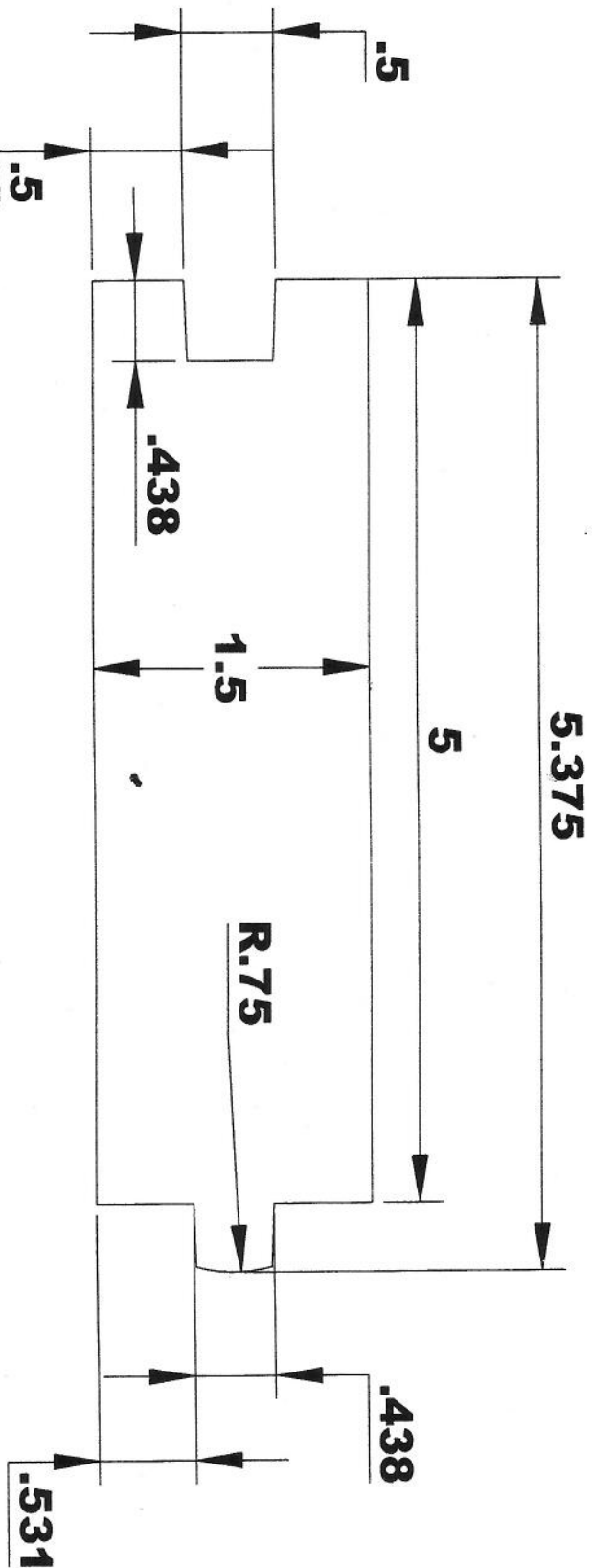
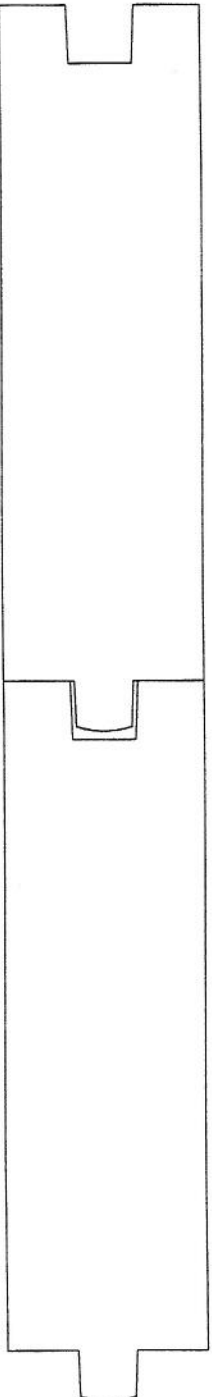

INSIDE OF MACHINE

OUTFEED VIEW COMING

SPECIFICATIONS

MOULDING # **TS-TG 4**

CUSTOMER: _____

COMMENTS: **20* HOOK**

MOULDER: 5/16 T-REX CORR., 1.5 START DEPTH, 10MM AXIALS

T-REX LONG WEAR

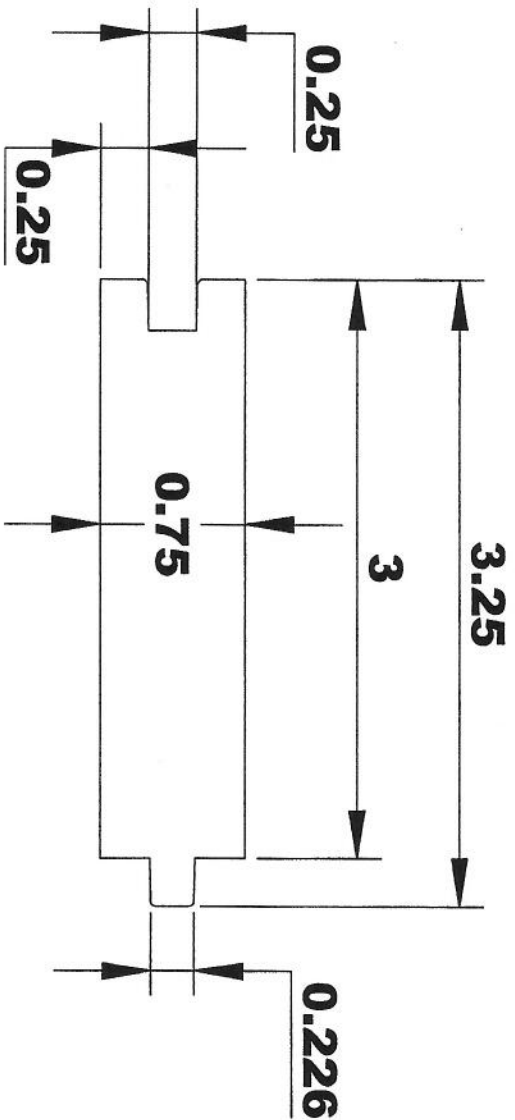
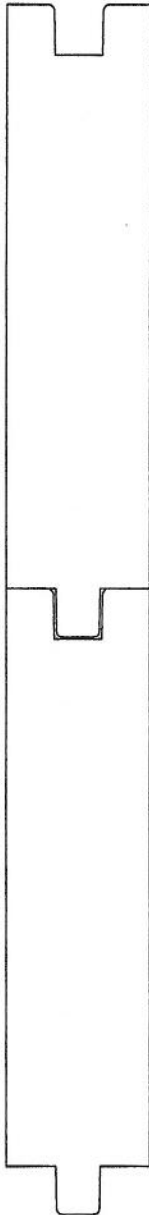

INSIDE OF MACHINE

OUTFEED VIEW COMING

SPECIFICATIONS

MOULDING # **TG 4**

CUSTOMER: _____

COMMENTS: **20* HOOK**

MOULDER: 5/16 T-REX CORR., 1.5 START DEPTH, 10MM AXIALS

T-REX LONG WEAR

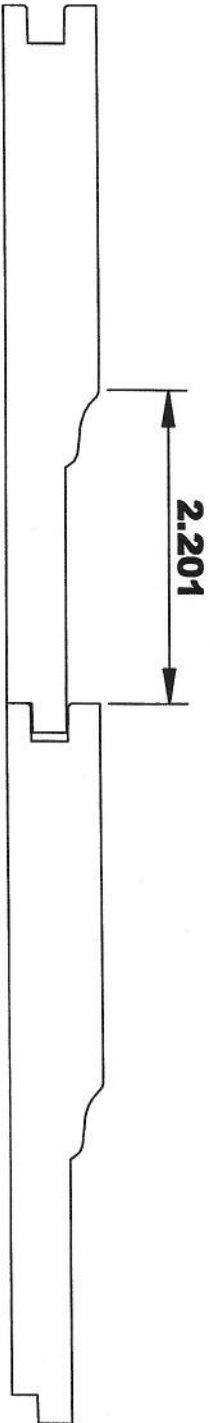

NOTE: USE TS-TG 4
GROOVE SIDE

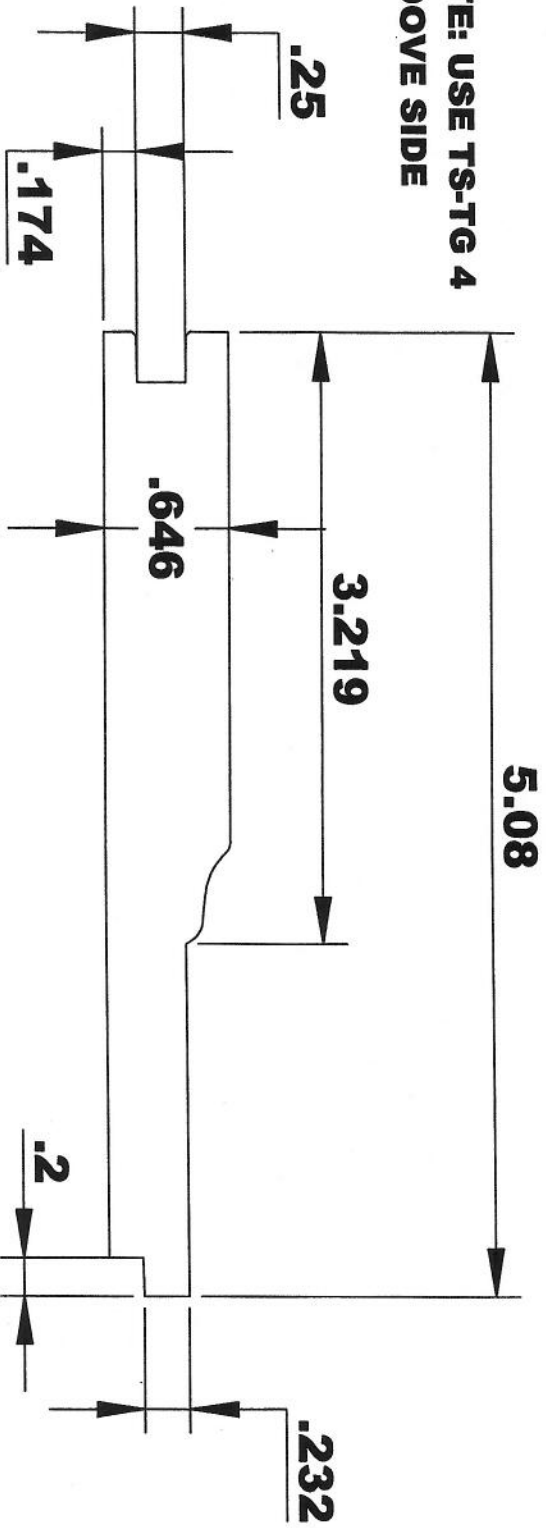

INSIDE OF MACHINE

OUTFEED VIEW COMING

SPECIFICATIONS

MOULDING # **TG 5**

CUSTOMER: _____

COMMENTS: **20* HOOK**

MOULDER: 5/16 T-REX CORR., 1.5 START DEPTH, 10MM AXIALS

T-REX LONG WEAR

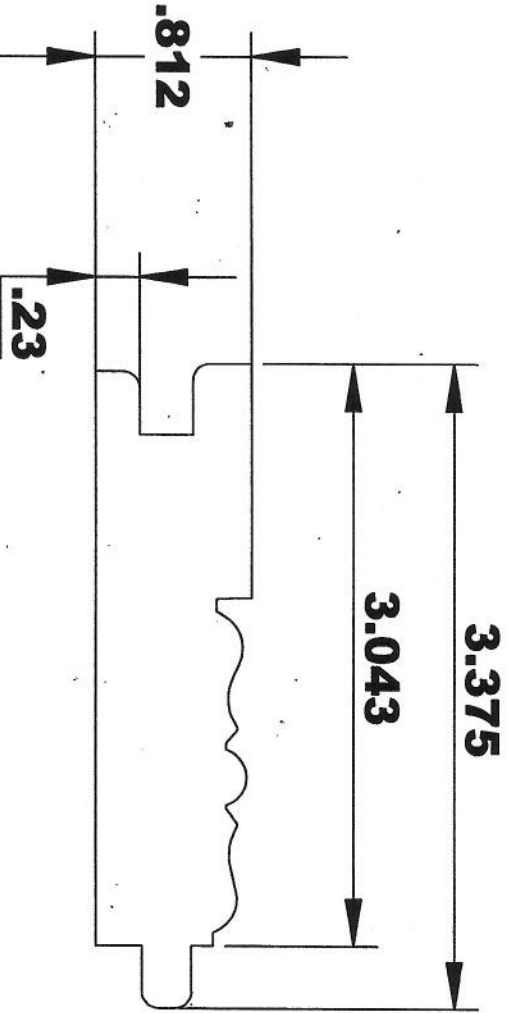
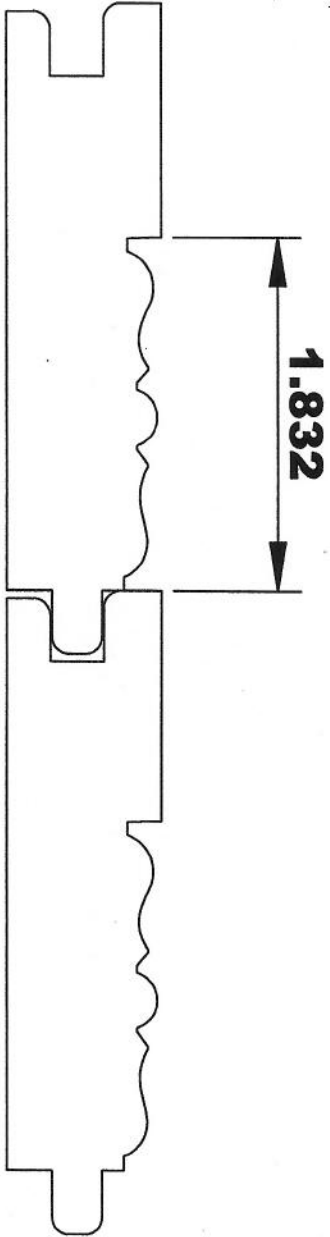

INSIDE OF MACHINE

OUTFEED VIEW COMING

SPECIFICATIONS

MOULDING # TG 6

CUSTOMER:

COMMENTS: 20* HOOK

MOULDER: 5/16 T-REX CORR., 1.5 START DEPTH, 10MM AXIALS
T-REX LONG WEAR

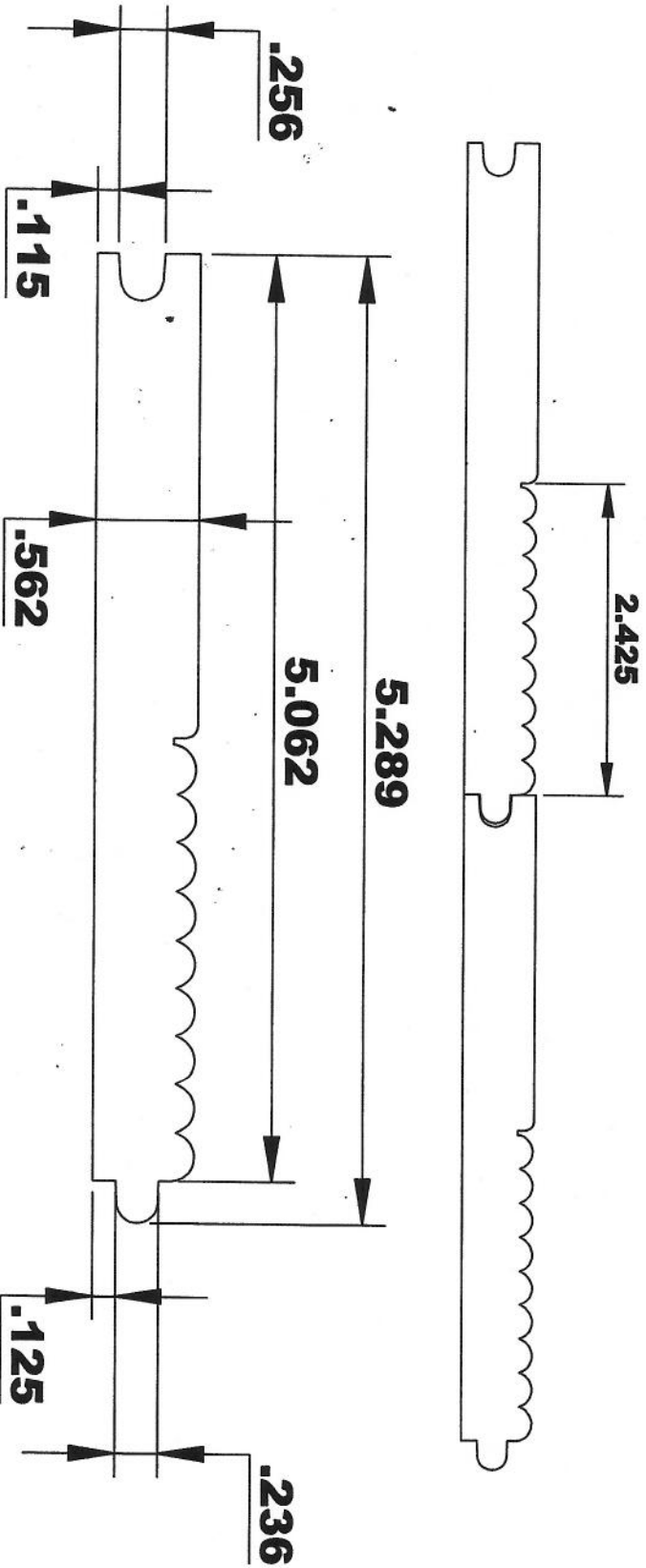

OUTFEED VIEW COMING

SPECIFICATIONS

MOULDING # **TG 8**

CUSTOMER: _____

COMMENTS: **20* HOOK**

MOULDER: 5/16 T-REX CORR., 1.5 START DEPTH, 10MM AXIALS
T-REX LONG WEAR

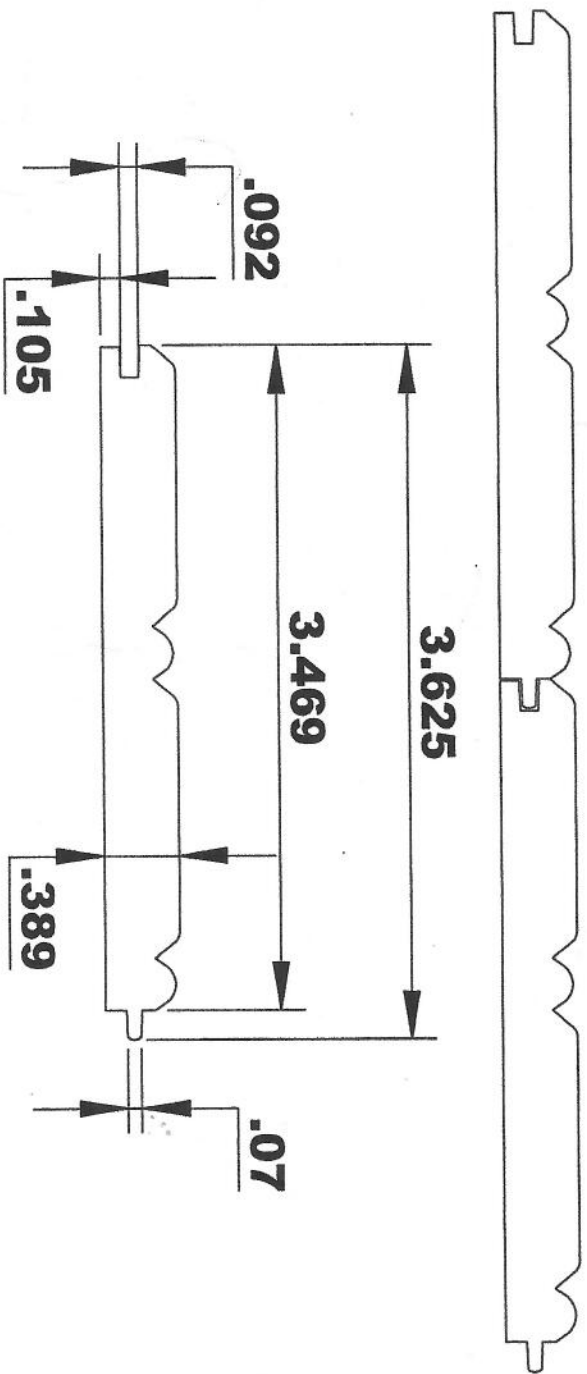
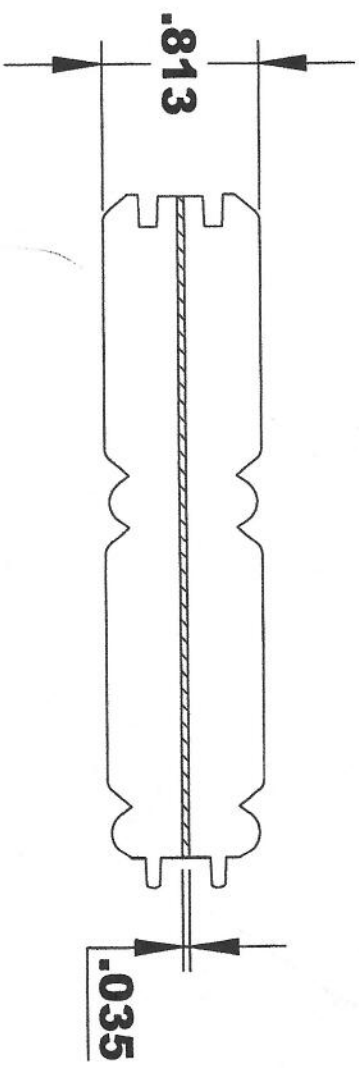

INSIDE OF MACHINE

OUTFEED VIEW COMING

SPECIFICATIONS

MOULDING # **TG 9**

CUSTOMER:

COMMENTS: **20° HOOK**

**MOULDER: 5/16 T-REX CORR., 1.5 START DEPTH, 10MM AXIALS
T-REX LONG WEAR**

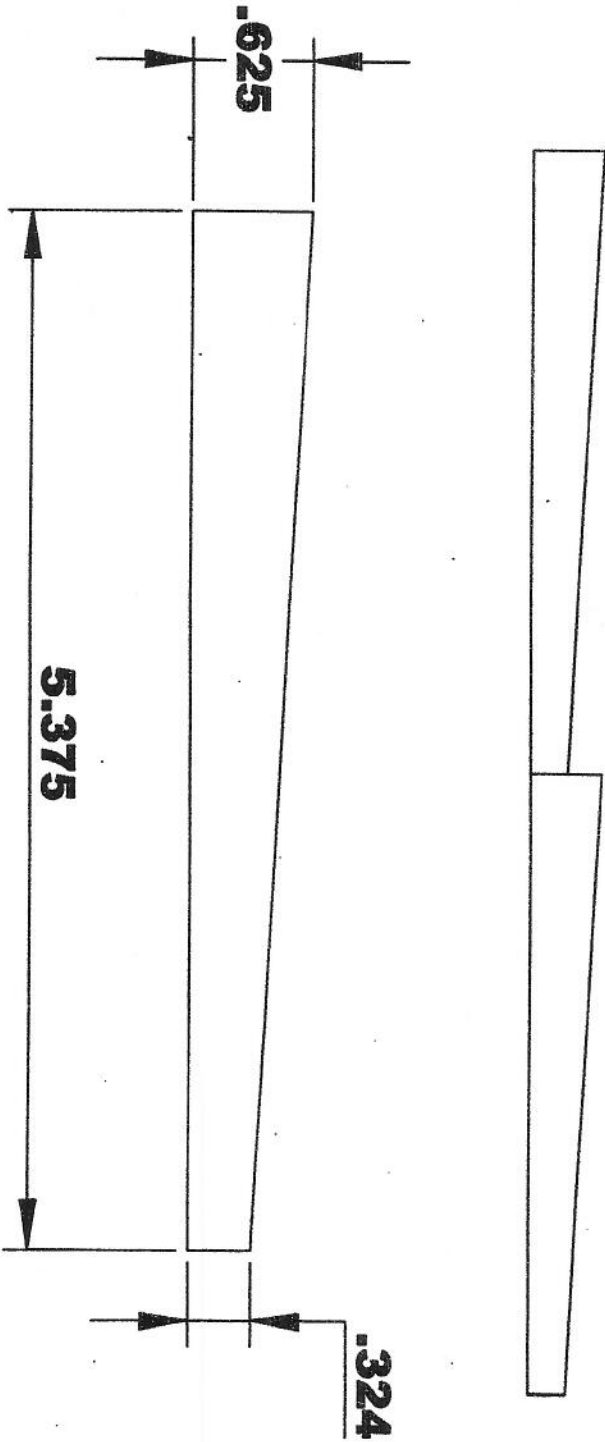

INSIDE OF MACHINE

OUTFEED VIEW COMING

SPECIFICATIONS

MOULDING # **TG 10**

CUSTOMER: _____

COMMENTS: **20* HOOK**

MOULDER: 5/16 T-REX CORR., 1.5 START DEPTH, 10MM AXIALS
T-REX LONG WEAR

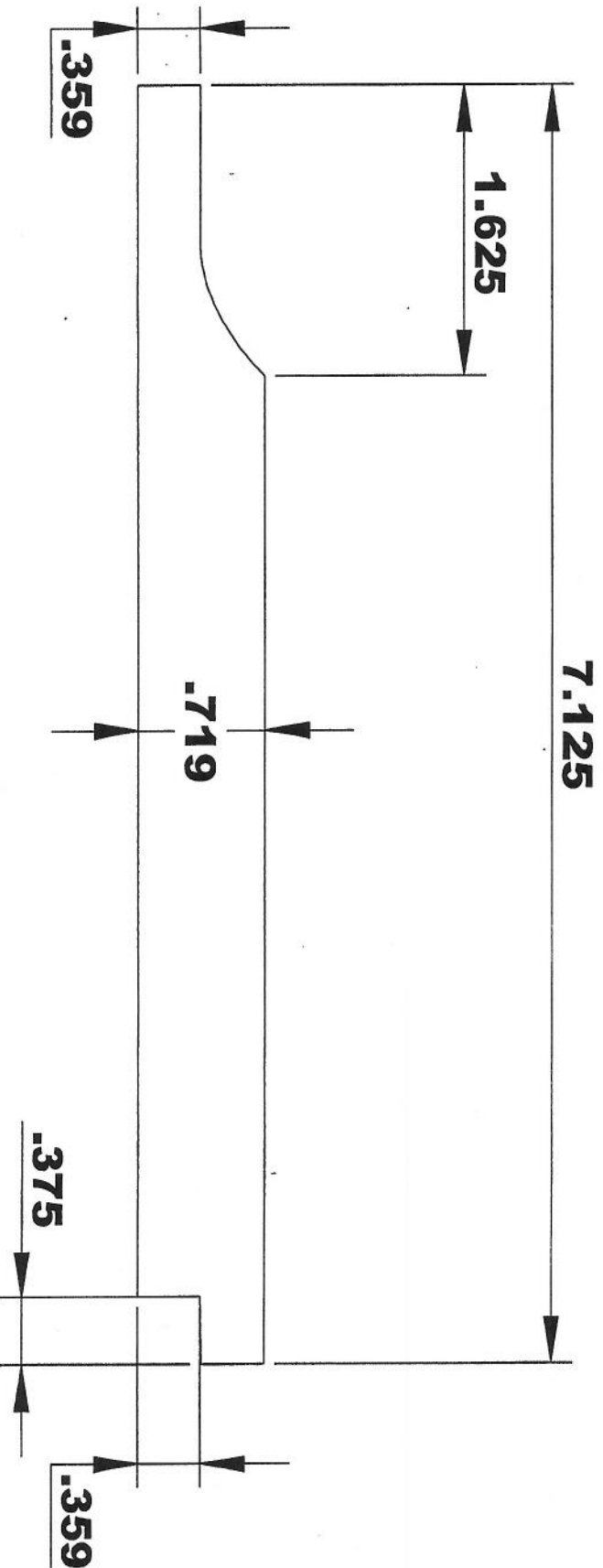
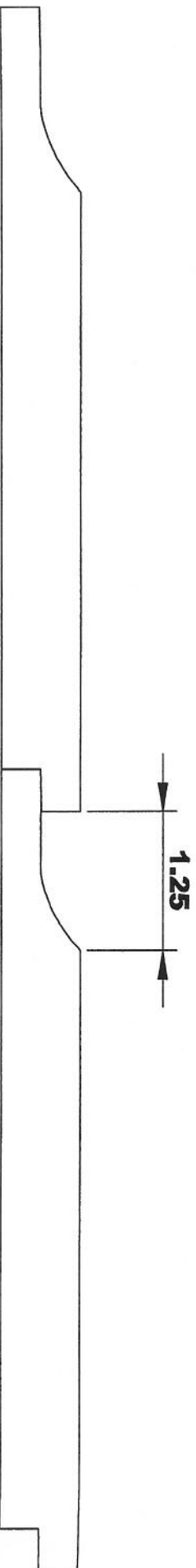

INSIDE OF MACHINE

OUTFEED VIEW COMING

SPECIFICATIONS

MOULDING # **TG 11**

CUSTOMER:

COMMENTS: **20* HOOK**

MOULDER: 5/16 T-REX CORR., 1.375 START DEPTH, 10MM AXIALS
T-REX LONG WEAR

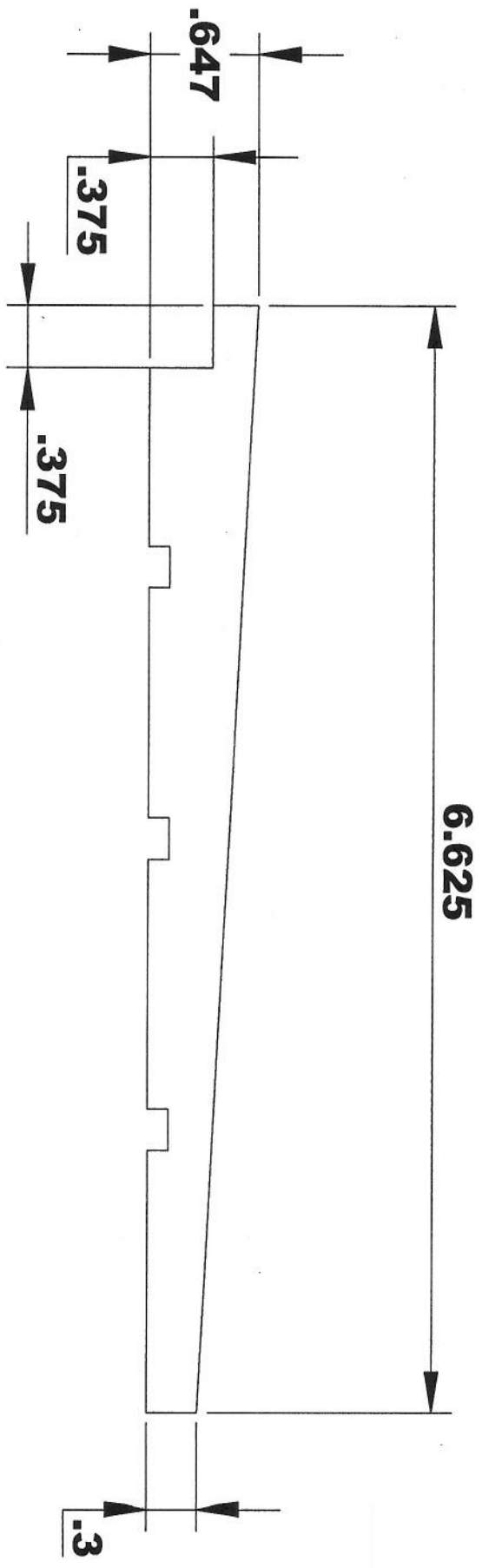
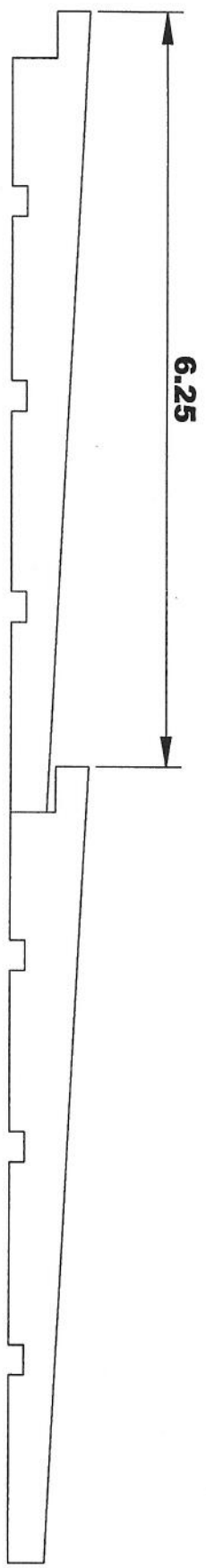

INSIDE OF MACHINE

OUTFEED VIEW COMING

SPECIFICATIONS

MOULDING # **TG 12**

CUSTOMER: _____

COMMENTS: **20 * HOOK**

MOULDER: 5/16 T-REX CORR., 1.375 START DEPTH, 10MM AXIALS
T-REX LONG WEAR

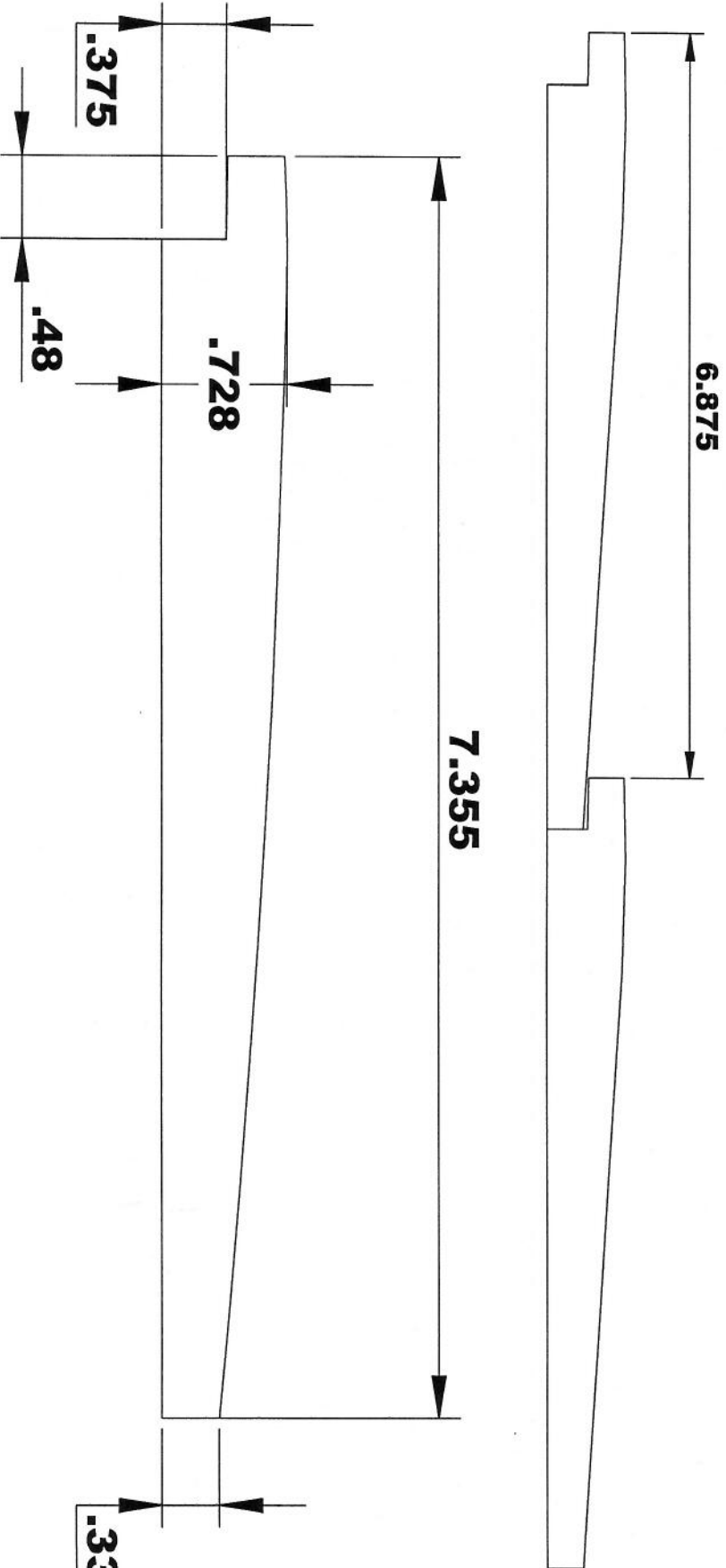

INSIDE OF MACHINE

OUTFEED VIEW COMING

SPECIFICATIONS

MOULDING # **TG 13**

CUSTOMER: _____

COMMENTS: **20* HOOK**

MOULDER: 5/16 T-REX CORR., 1.375 START DEPTH, 10MM AXIALS
T-REX LONG WEAR

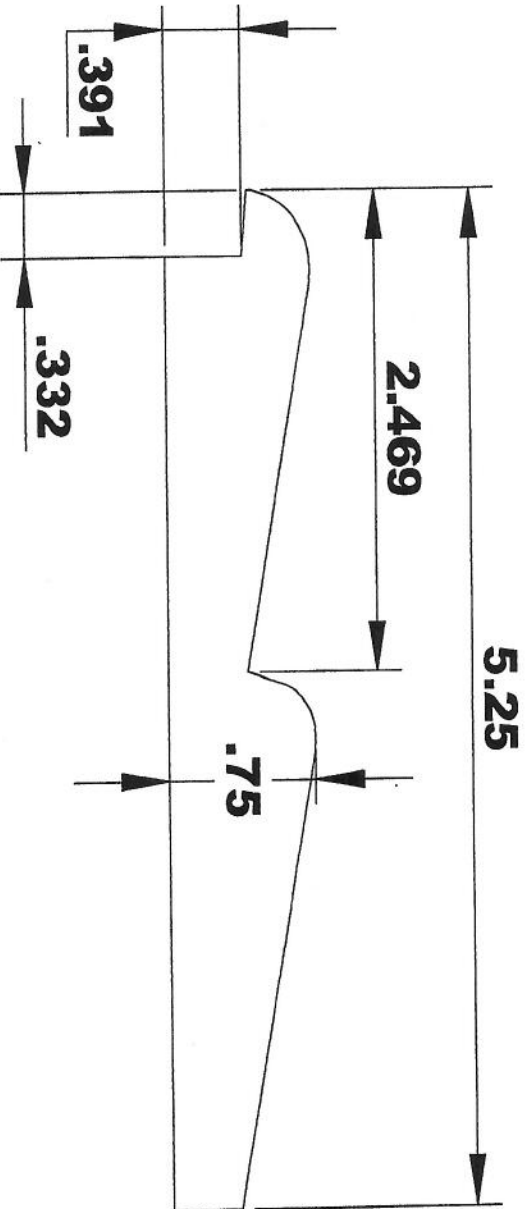
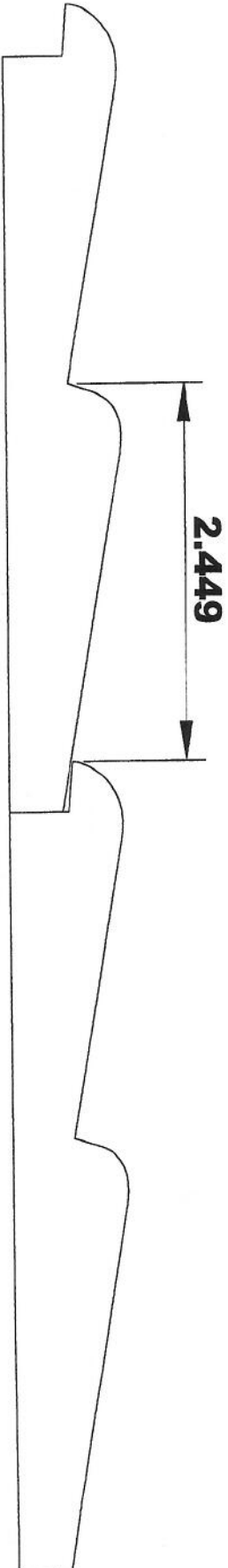

INSIDE OF MACHINE

OUTFEED VIEW COMING

SPECIFICATIONS

MOULDING # **TG 15**

CUSTOMER: _____

COMMENTS: **20* HOOK**

MOULDER: 5/16 T-REX CORR., 1.5 START DEPTH, 10MM AXIALS

T-REX LONG WEAR

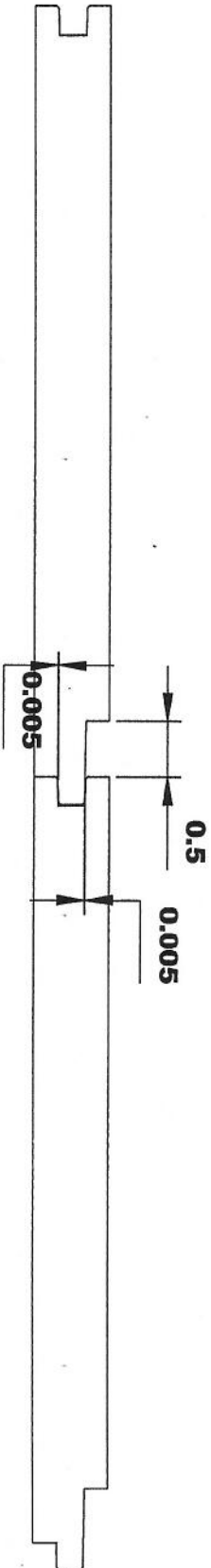

USE TS TG 4
FOR GROOVE

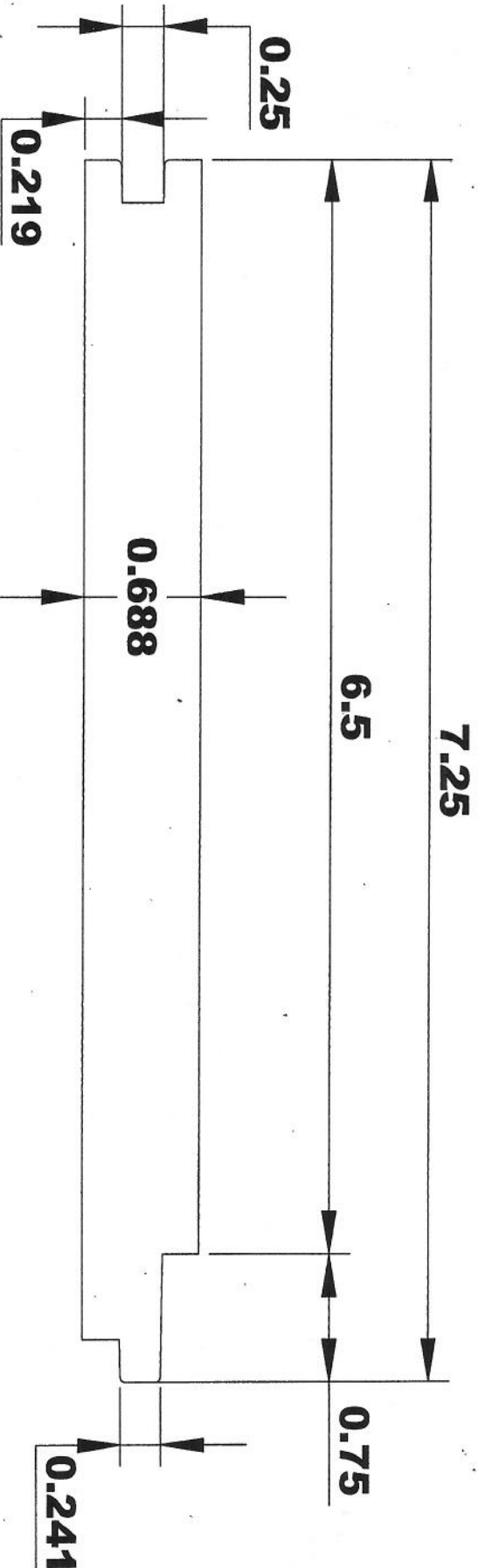

INSIDE OF MACHINE

OUTFEED VIEW COMING

SPECIFICATIONS

MOULDING # **TG 16**

CUSTOMER: _____

COMMENTS: **20 * HOOK**

MOULDER: 5/16 T-REX CORR., 1.5 START DEPTH, 10MM AXIALS
T-REX LONG WEAR

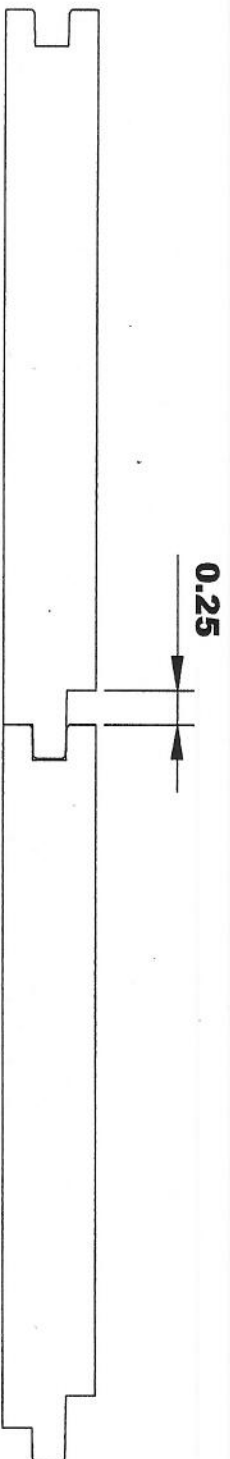

USE TS TG 4
FOR GROOVE

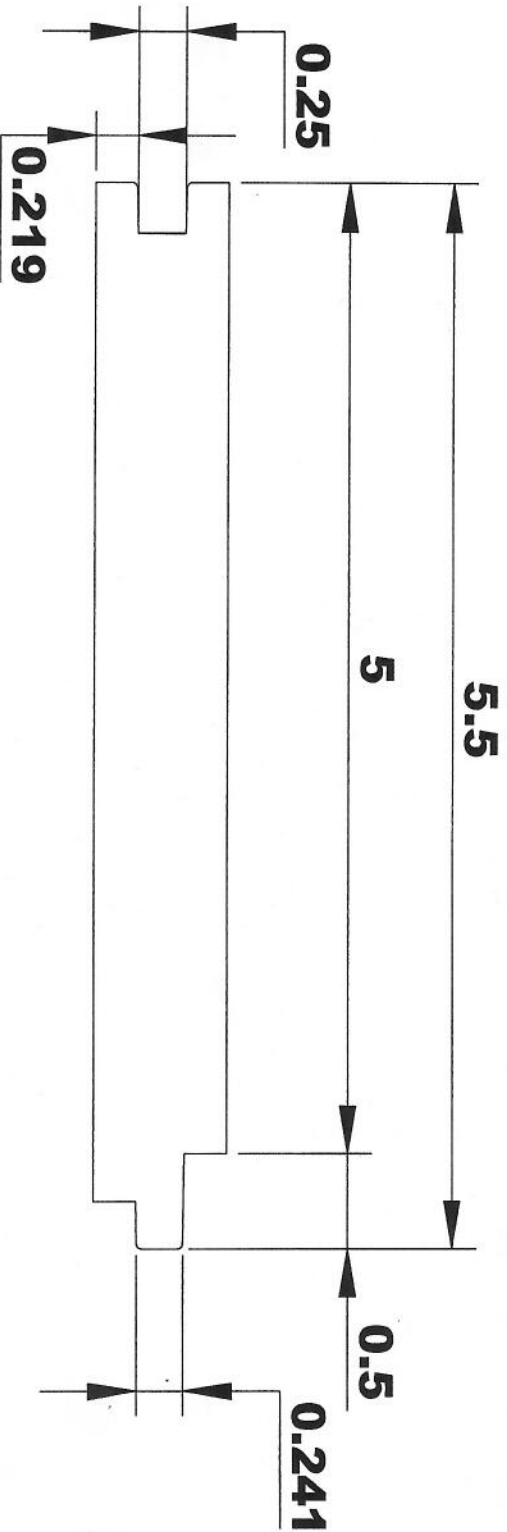

INSIDE OF MACHINE

OUTFEED VIEW COMING

SPECIFICATIONS

MOULDING # **TG 17**

CUSTOMER: _____

COMMENTS: **20* HOOK**

MOULDER: 5/16 T-REX CORR., 1.5 START DEPTH, 10MM AXIALS
T-REX LONG WEAR

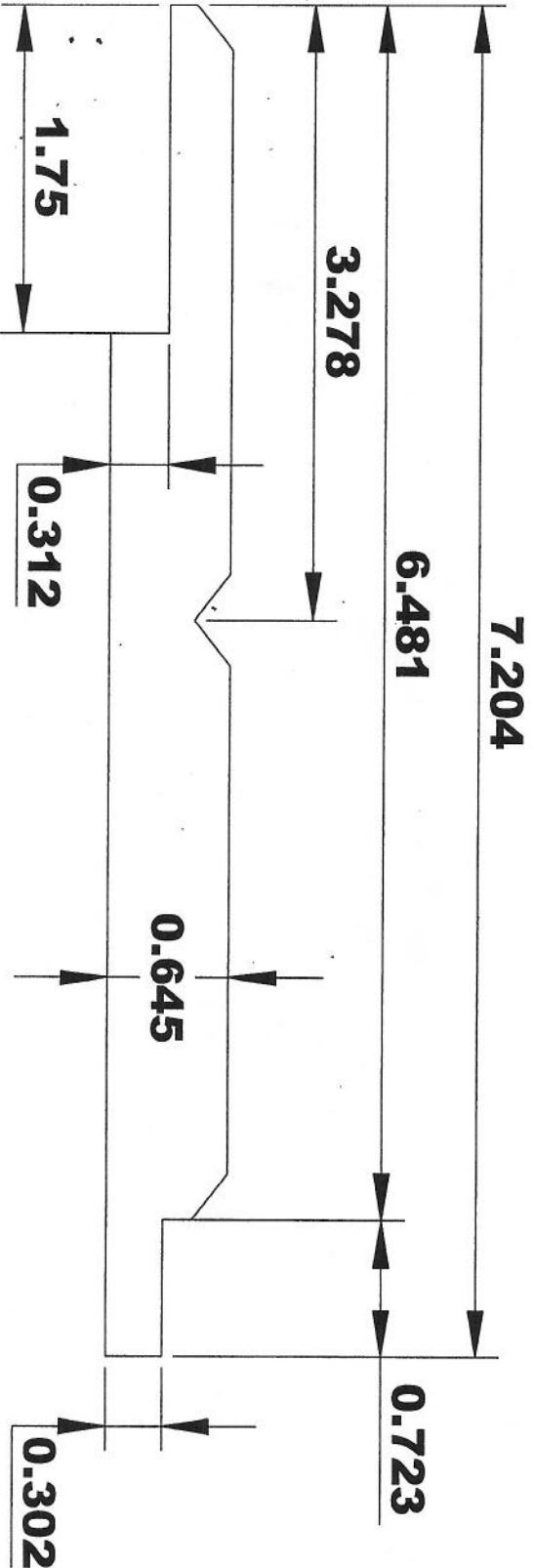
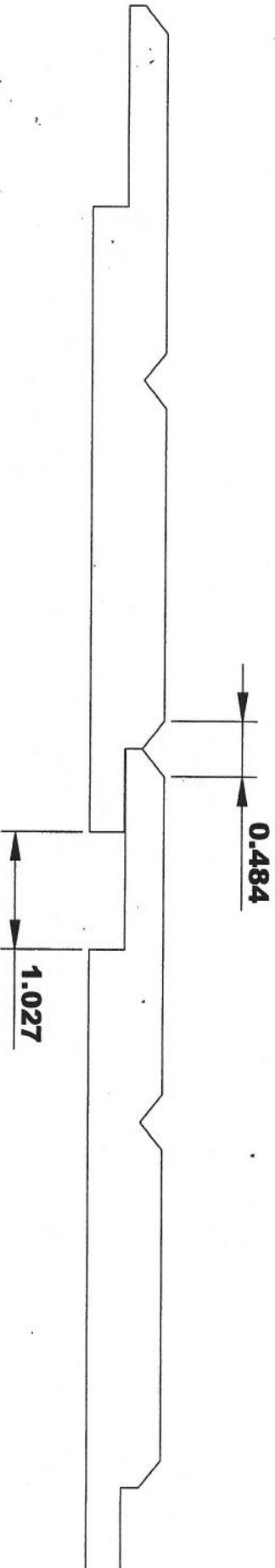

INSIDE OF MACHINE

OUTFEED VIEW COMING

SPECIFICATIONS

MOULDING # **TG 18**

CUSTOMER:

COMMENTS: **20 * HOOK**

MOULDER: 5/16 T-REX CORR., 1.5 START DEPTH, 10MM AXIALS
T-REX LONG WEAR

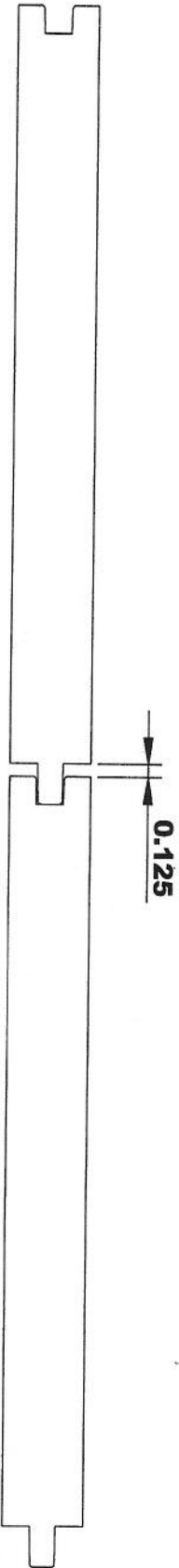

USE
TS-TG 4

FOR INSIDE
KNIVES

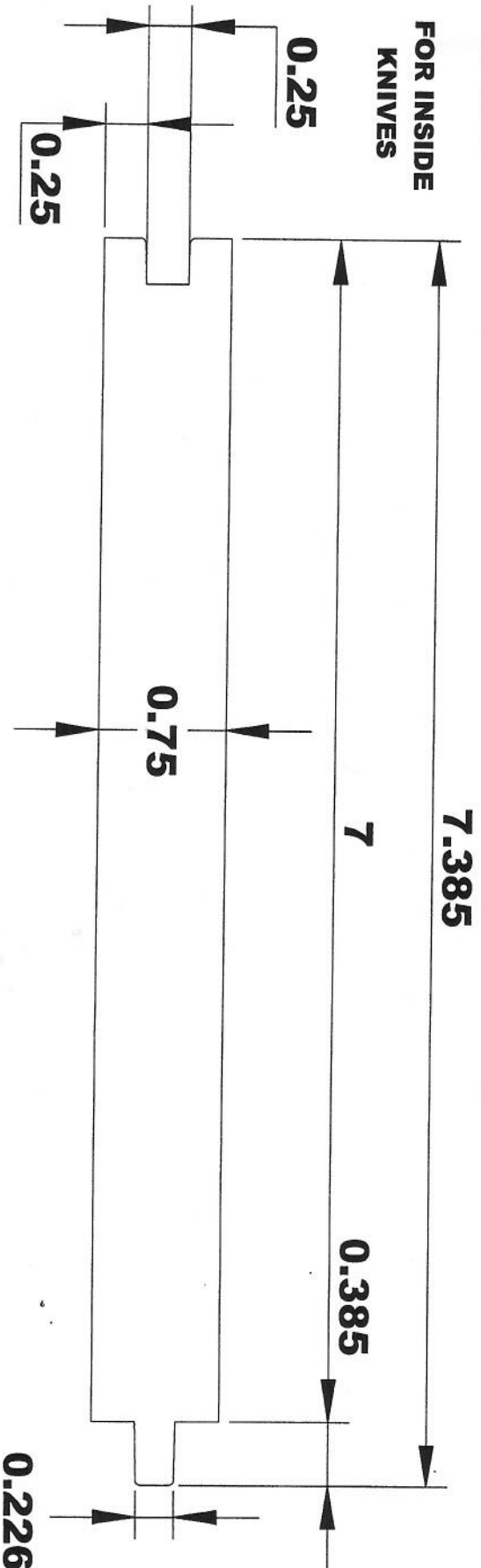

INSIDE OF MACHINE

OUTFEED VIEW COMING

SPECIFICATIONS

MOULDING # **TG 19**

CUSTOMER: _____

COMMENTS: **20* HOOK**

MOULDER: 5/16 T-REX CORR., 1.5 START DEPTH, 10MM AXIALS
T-REX LONG WEAR

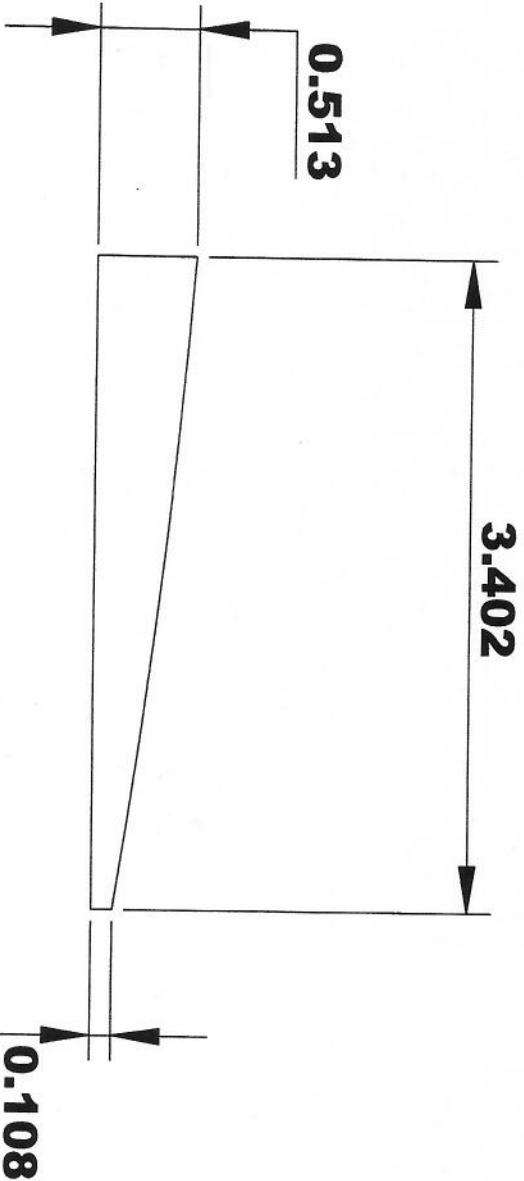

INSIDE OF MACHINE

OUTFEED VIEW COMING

SPECIFICATIONS

MOULDING # **TG 20**

CUSTOMER: _____

COMMENTS: **20 * HOOK**

MOULDER: 5/16 T-REX CORR., 1.375 START DEPTH, 10MM AXIALS
T-REX LONG WEAR

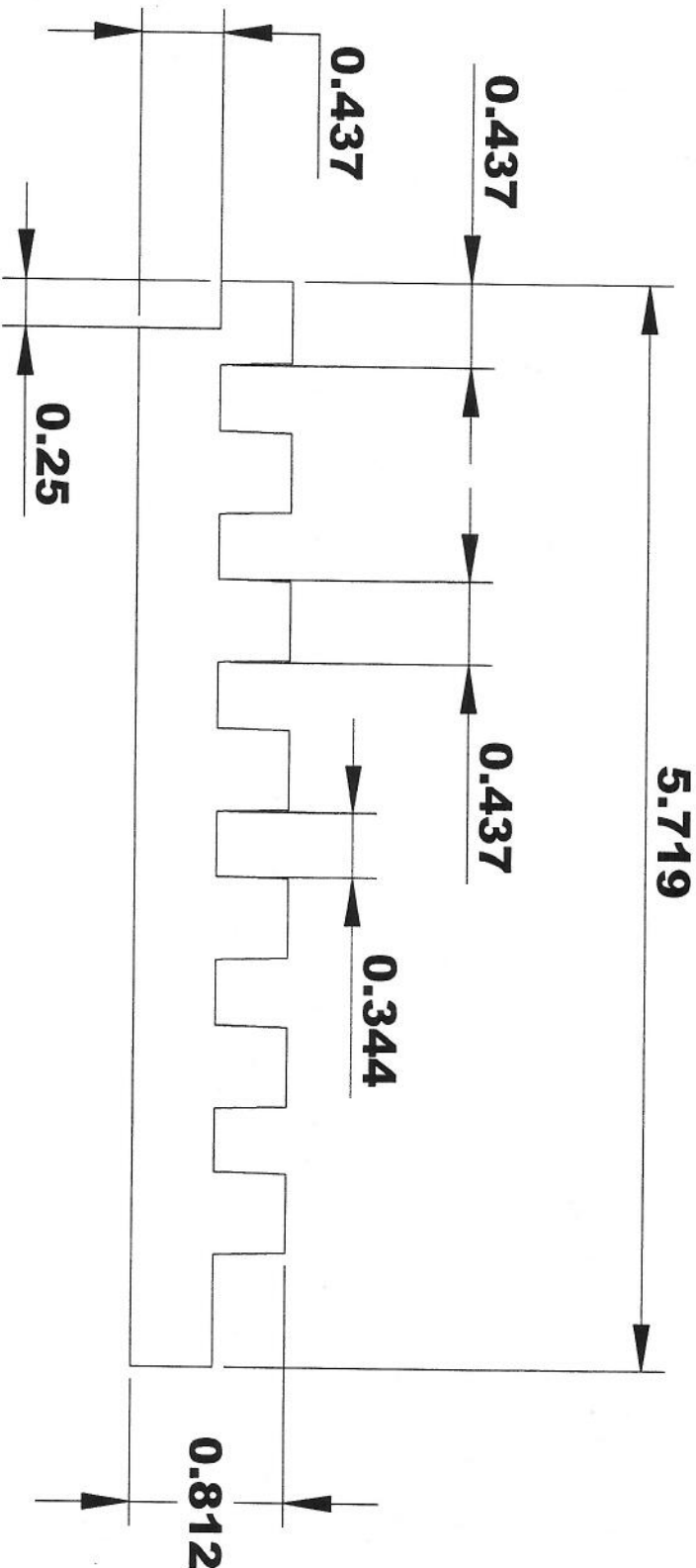
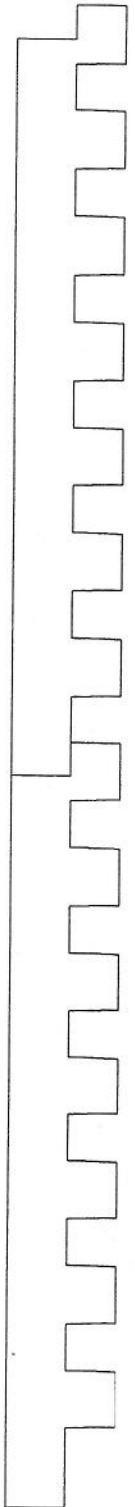

OUTFEED VIEW COMING

INSIDE OF MACHINE

SPECIFICATIONS

MOULDING # **TG 21**

CUSTOMER: _____

COMMENTS: **20* HOOK**

MOULDER: 5/16 T-REX CORR., 1.375 START DEPTH, 10MM AXIALS
T-REX LONG WEAR

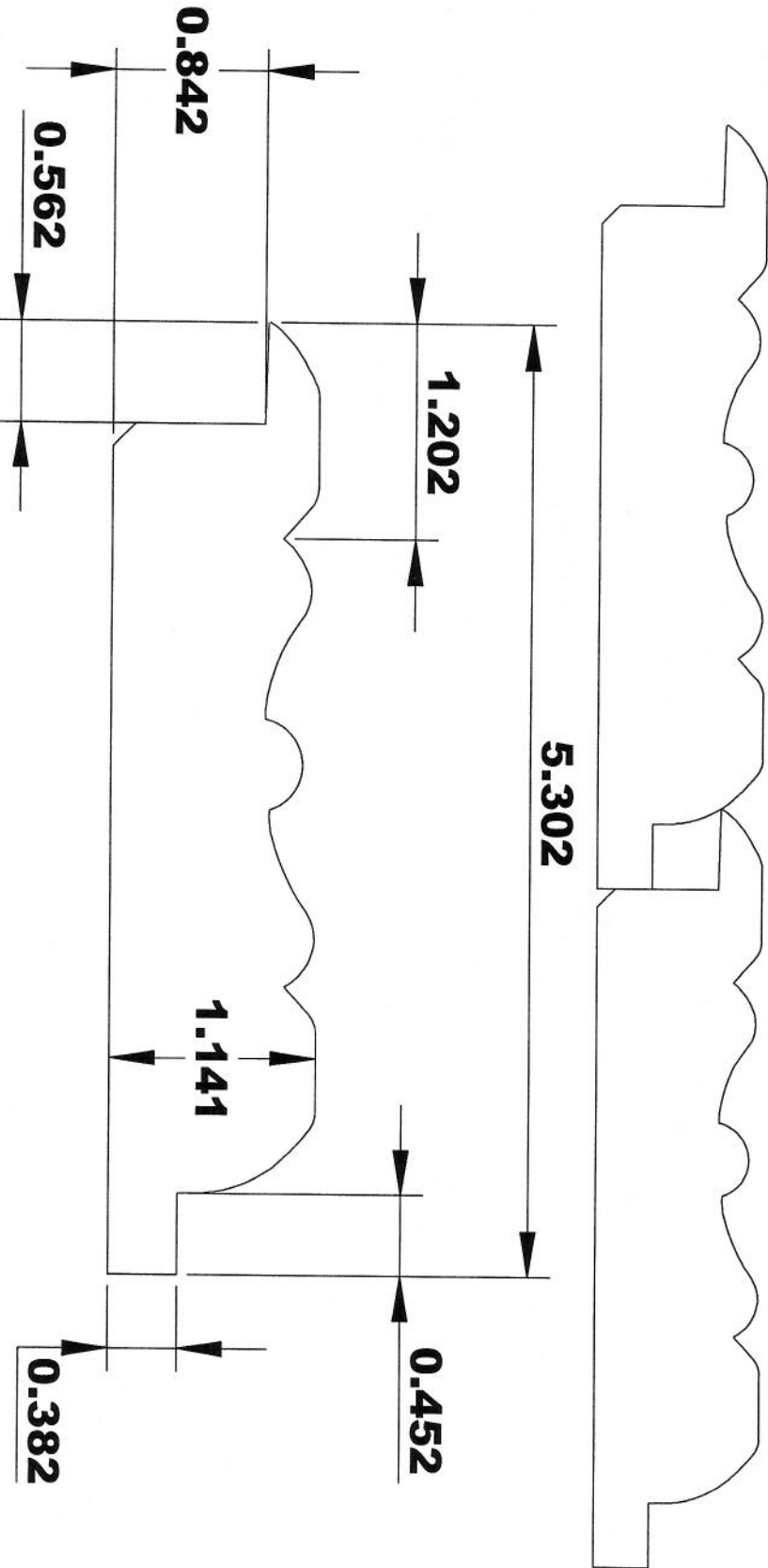

INSIDE OF MACHINE

OUTFEED VIEW COMING

SPECIFICATIONS

MOULDING # **S & R 2**

CUSTOMER: _____

COMMENTS: **20* HOOK**

MOULDER: 5/16 T-REX CORR., 1.375 START DEPTH, 10MM AXIALS

T-REX LONG WEAR

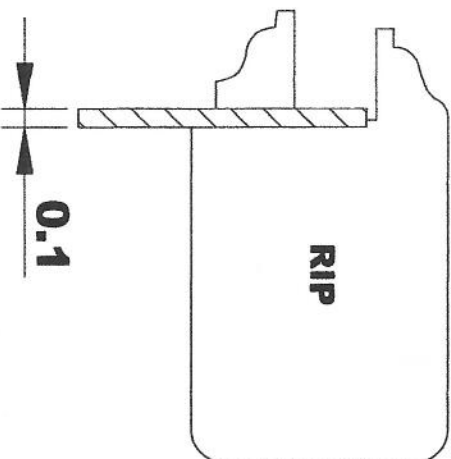
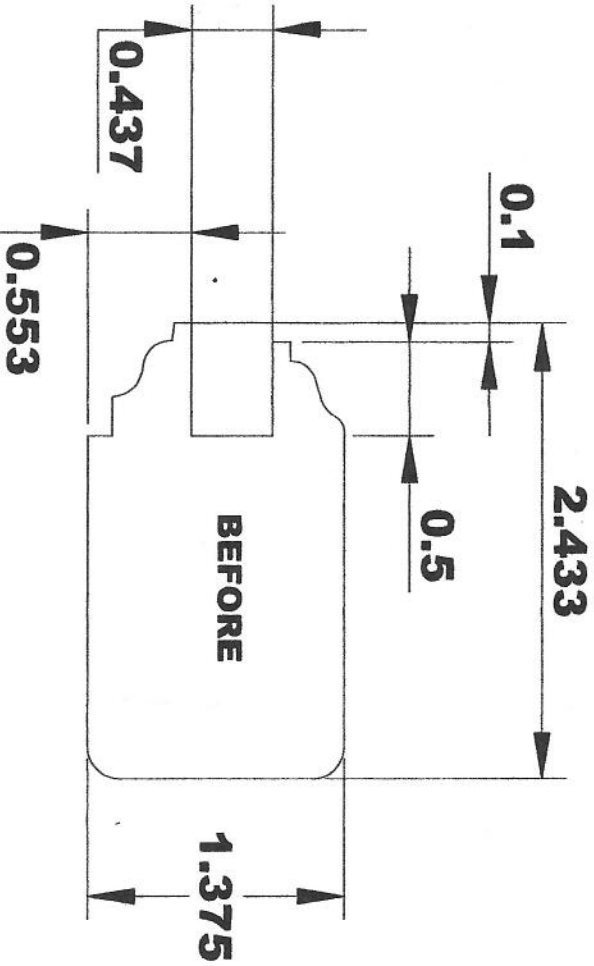
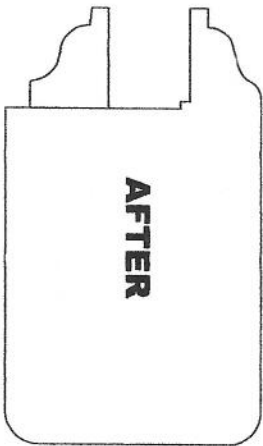

INSIDE OF MACHINE

OUTFEED VIEW COMING

SPECIFICATIONS

MOULDING # **BNDR RA 1**

CUSTOMER: _____

COMMENTS: **20* HOOK**

MOULDER: 5/16 T-REX CORR., 1.5 START DEPTH, 10MM AXIALS
T-REX LONG WEAR

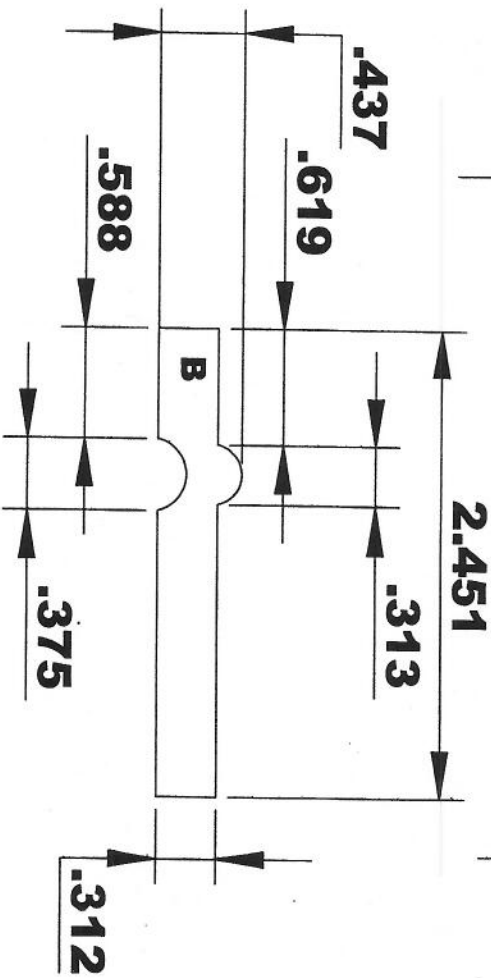
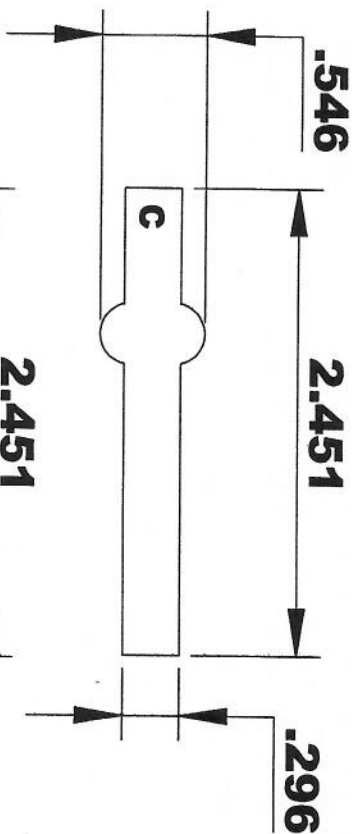
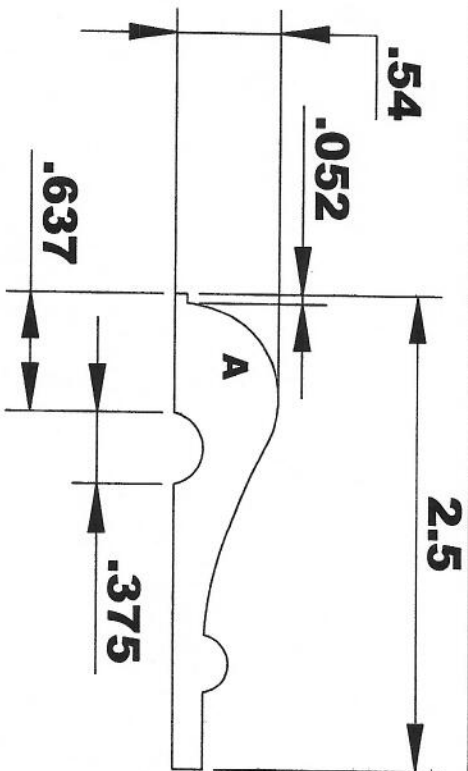
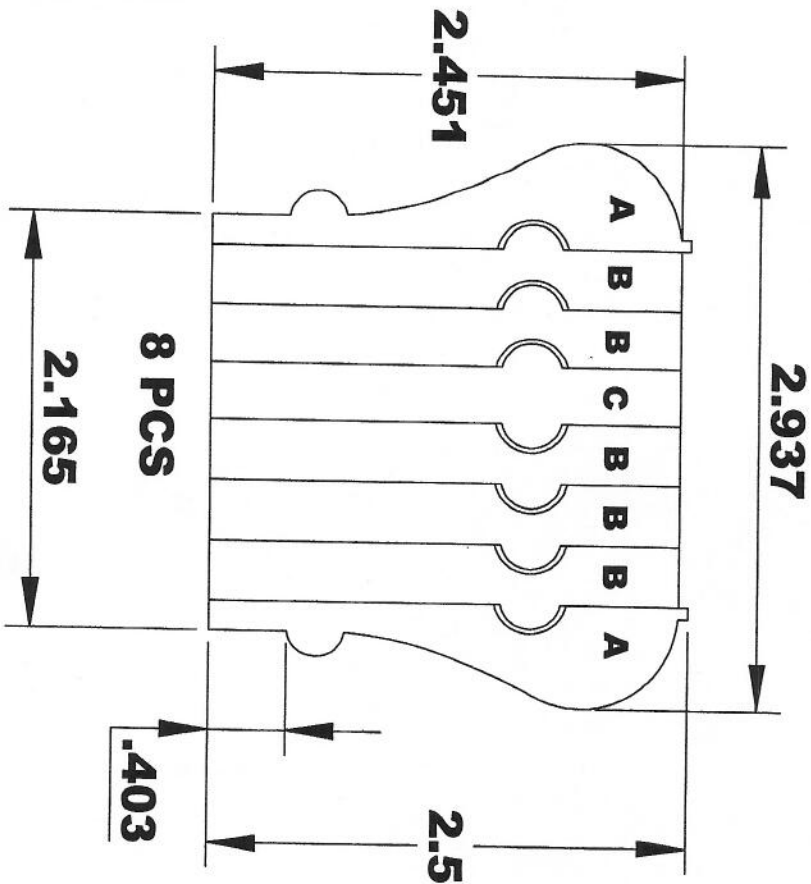

INSIDE OF MACHINE

OUTFEED VIEW COMING