

Wes Vice Hardwoods
& Supply Inc.
Nederland, Texas



Panel
Mouldings

SPECIFICATIONS

MOULDING # PA 1

CUSTOMER: _____

COMMENTS: 20 * HOOK

MOULDER: 5/16 T-REX CORR., 1.5 START DEPTH, 10MM AXIALS

T-REX LONG WEAR

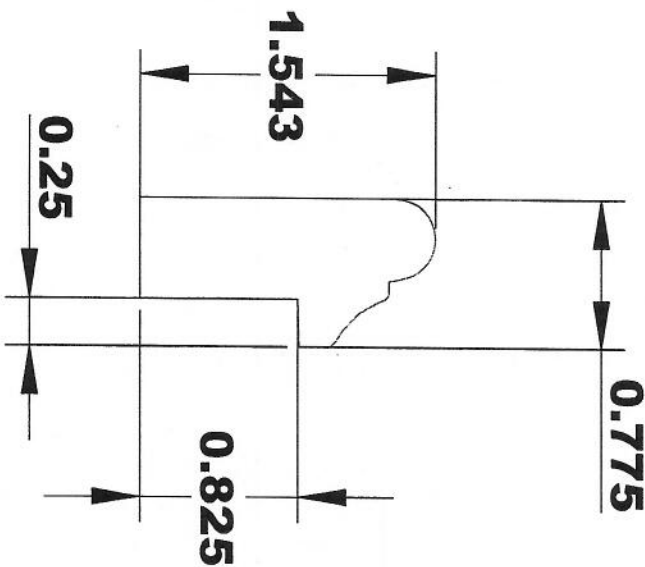
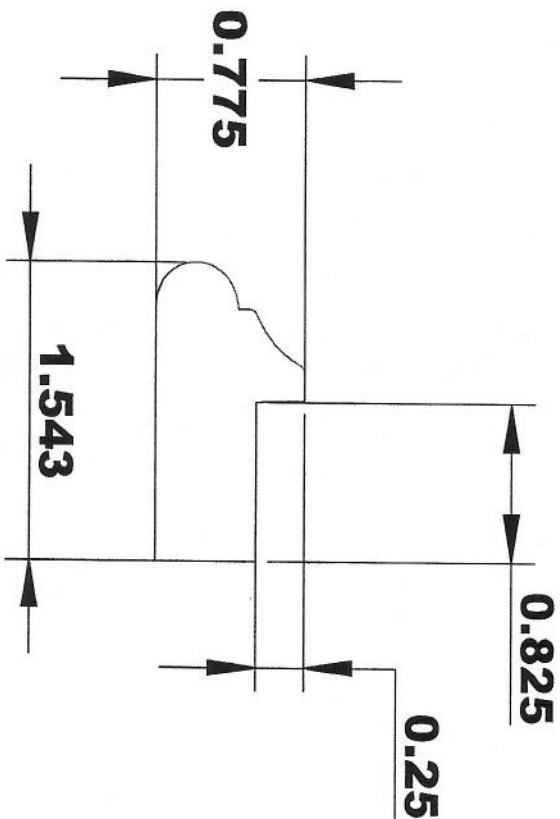

INSIDE OF MACHINE

OUTFEED VIEW COMING

SPECIFICATIONS

MOULDING # PA 2

CUSTOMER: _____

COMMENTS: 20* HOOK

MOULDER: 5/16 T-REX CORR., 1.5 START DEPTH, 10MM AXIALS

T-REX LONG WEAR

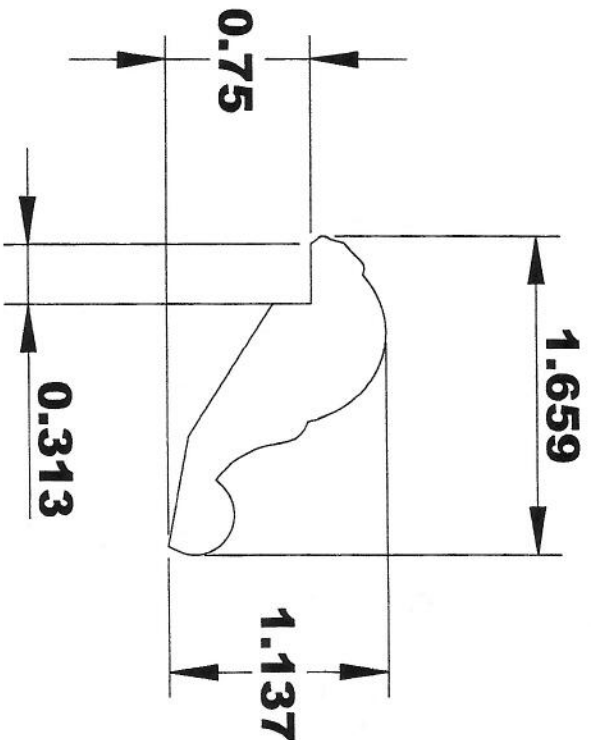

INSIDE OF MACHINE

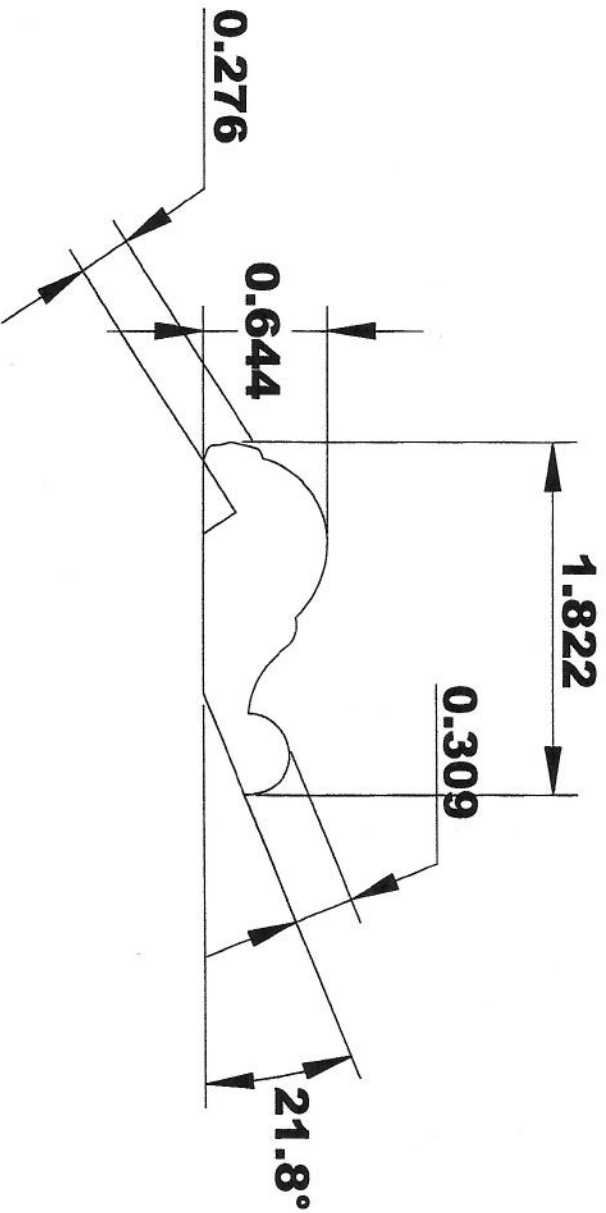

OUTFEED VIEW COMING

SPECIFICATIONS

MOULDING # PA 3

CUSTOMER: _____

COMMENTS: 20* HOOK

MOULDER: 5/16 T-REX CORR., 1.5 START DEPTH, 10MM AXIALS
T-REX LONG WEAR

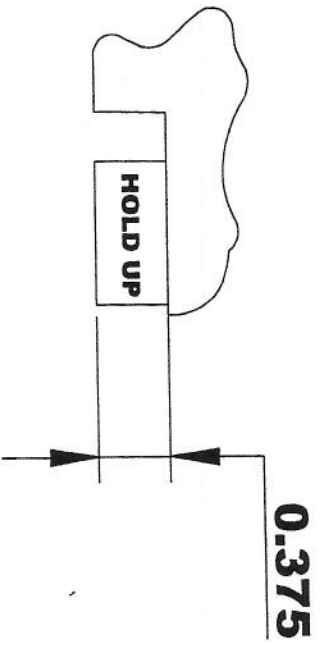

**MUST USE HOLD UP AFTER LAST BOTTOM
HEAD CUTS RABBIT**

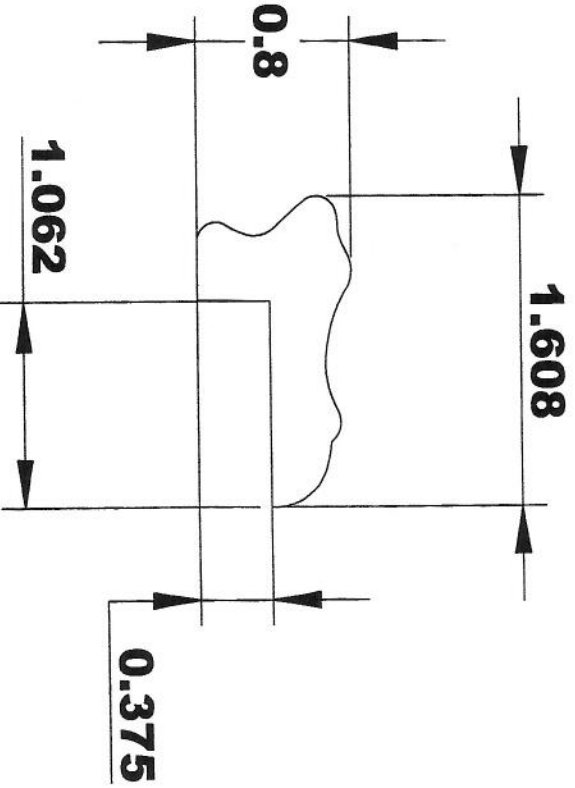

INSIDE OF MACHINE

OUTFEED VIEW COMING

SPECIFICATIONS

MOULDING # **PA 4**

CUSTOMER: _____

COMMENTS: **20 * HOOK**

MOULDER: 5/16 T-REX CORR., 1.5 START DEPTH, 10MM AXIALS
T-REX LONG WEAR

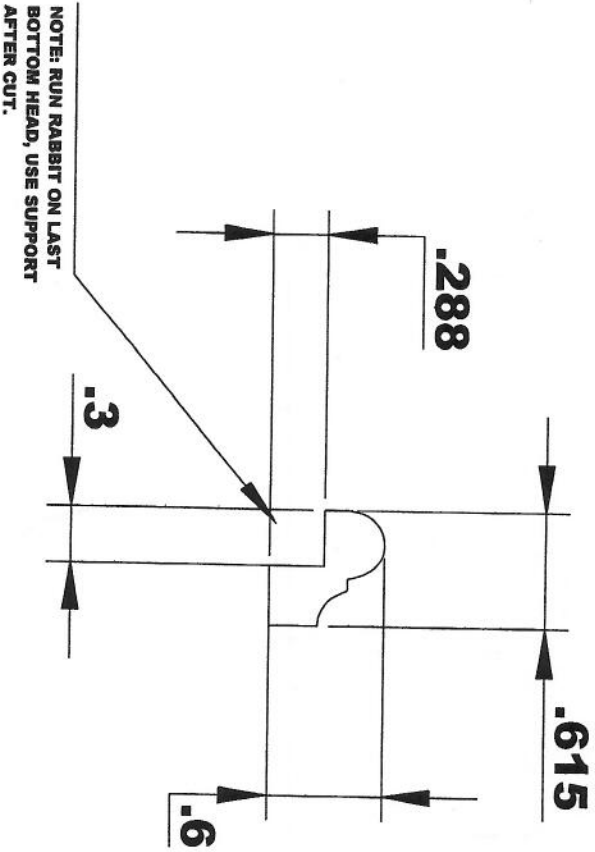

INSIDE OF MACHINE

OUTFEED VIEW COMING

SPECIFICATIONS

MOULDING # **PA 5**

CUSTOMER: _____

COMMENTS: **20 * HOOK**

MOULDER: 5/16 T-REX CORR., 1.5 START DEPTH, 10MM AXIALS
T-REX LONG WEAR

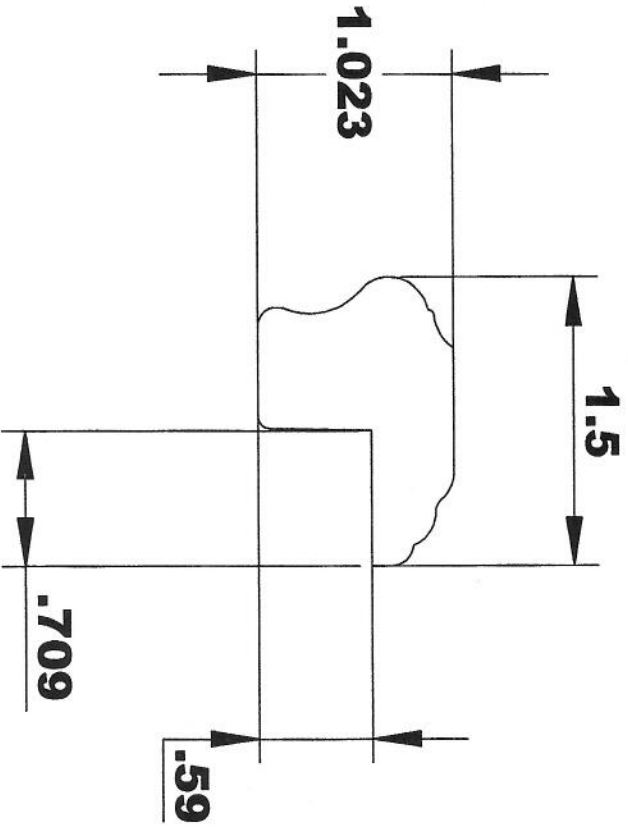

INSIDE OF MACHINE

OUTFEED VIEW COMING

SPECIFICATIONS

MOULDING # **PA 6**

CUSTOMER: _____

COMMENTS: **20* HOOK**

MOULDER: 5/16 T-REX CORR., 1.5 START DEPTH, 10MM AXIALS
T-REX LONG WEAR

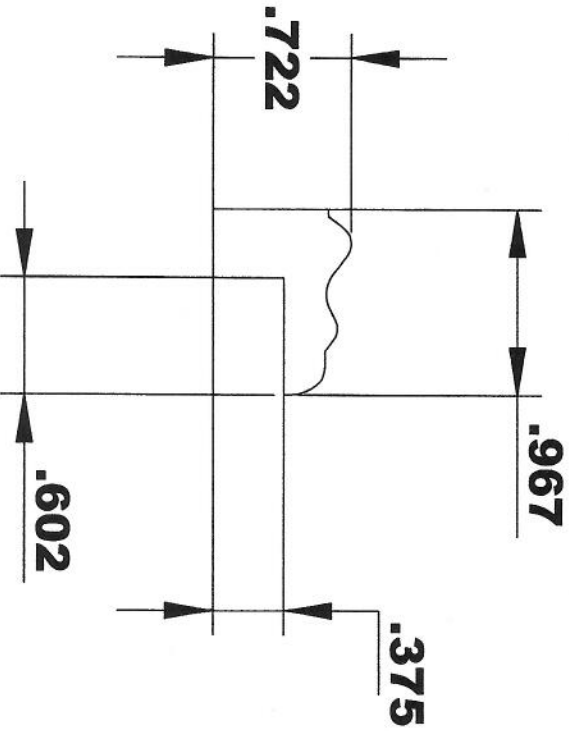

INSIDE OF MACHINE

OUTFEED VIEW COMING

SPECIFICATIONS

MOULDING # PA 7

CUSTOMER: _____

COMMENTS: 20* HOOK

MOULDER: 5/16 T-REX CORR., 1.5 START DEPTH, 10MM AXIALS
T-REX LONG WEAR

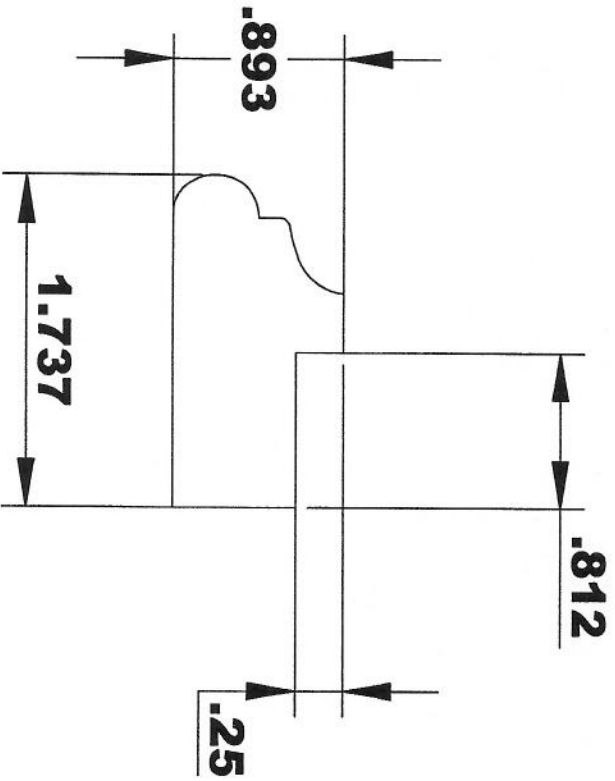

INSIDE OF MACHINE

OUTFEED VIEW COMING

SPECIFICATIONS

MOULDING # **PA 8**

CUSTOMER: _____

COMMENTS: **20 * HOOK**

MOULDER: 5/16 T-REX CORR., 1.5 START DEPTH, 10MM AXIALS

T-REX LONG WEAR

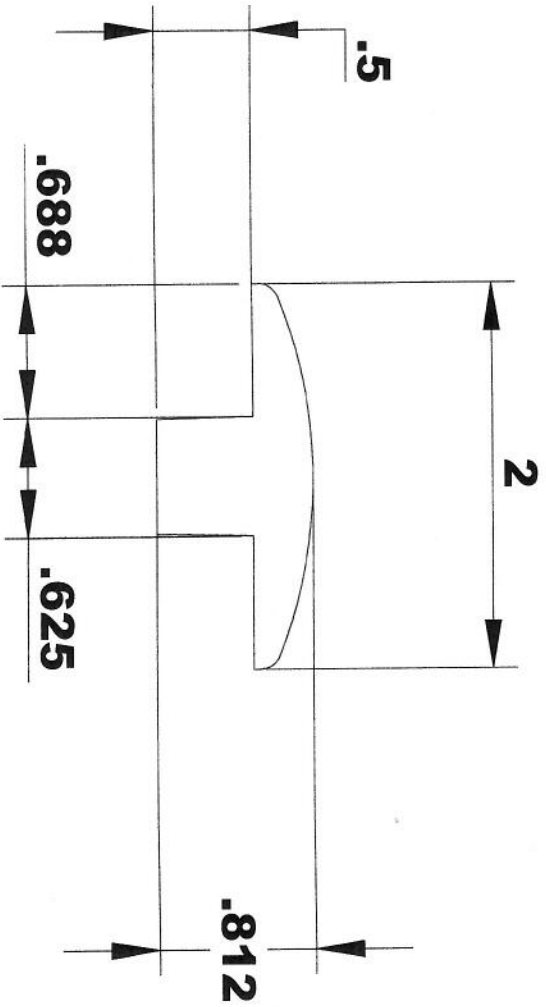

INSIDE OF MACHINE

OUTFEED VIEW COMING

SPECIFICATIONS

MOULDING # **PA 9**

CUSTOMER: _____

COMMENTS: **20 * HOOK**

MOULDER: 5/16 T-REX CORR., 1.5 START DEPTH, 10MM AXIALS
T-REX LONG WEAR

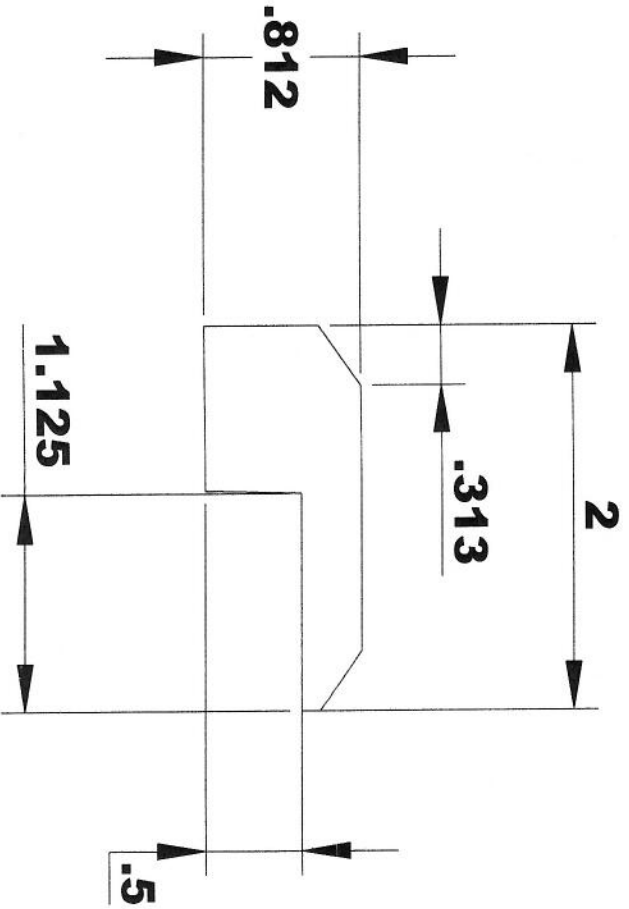

INSIDE OF MACHINE

OUTFEED VIEW COMING

SPECIFICATIONS

MOULDING # **PA 10**

CUSTOMER: _____

COMMENTS: **20 * HOOK**

MOULDER: 5/16 T-REX CORR., 1.5 START DEPTH, 10MM AXIALS
T-REX LONG WEAR

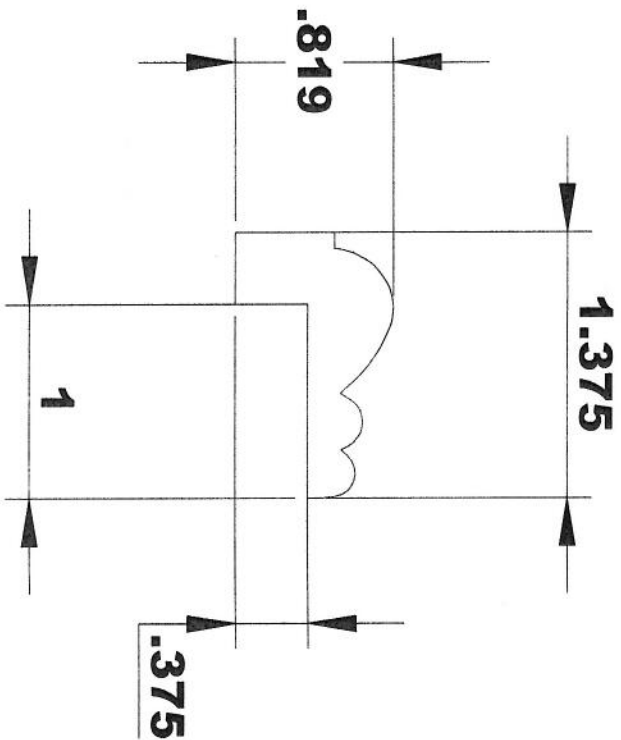

INSIDE OF MACHINE

OUTFEED VIEW COMING

SPECIFICATIONS

MOULDING # **PA 11**

CUSTOMER: _____

COMMENTS: **20* HOOK**

MOULDER: 5/16 T-REX CORR., 1.5 START DEPTH, 10MM AXIALS
T-REX LONG WEAR

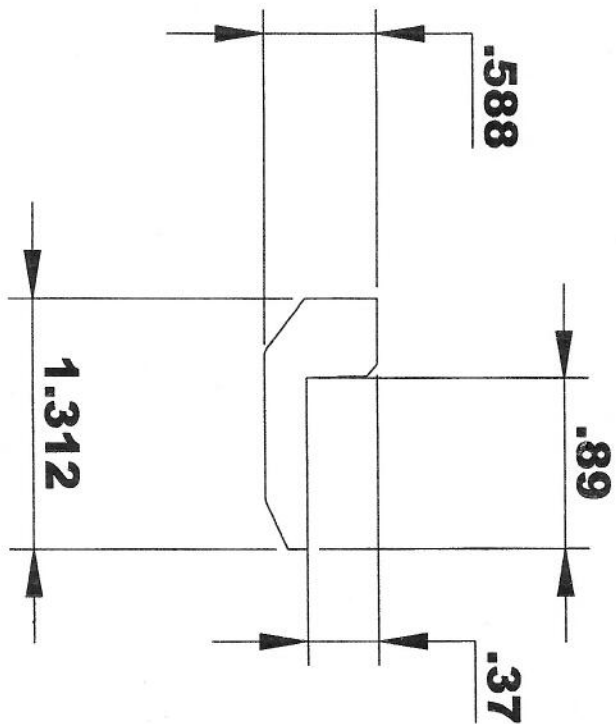

INSIDE OF MACHINE

OUTFEED VIEW COMING

SPECIFICATIONS

MOULDING # **PA 12**

CUSTOMER: _____

COMMENTS: **20* HOOK**

MOULDER: 5/16 T-REX CORR., 1.5 START DEPTH, 10MM AXIALS

T-REX LONG WEAR

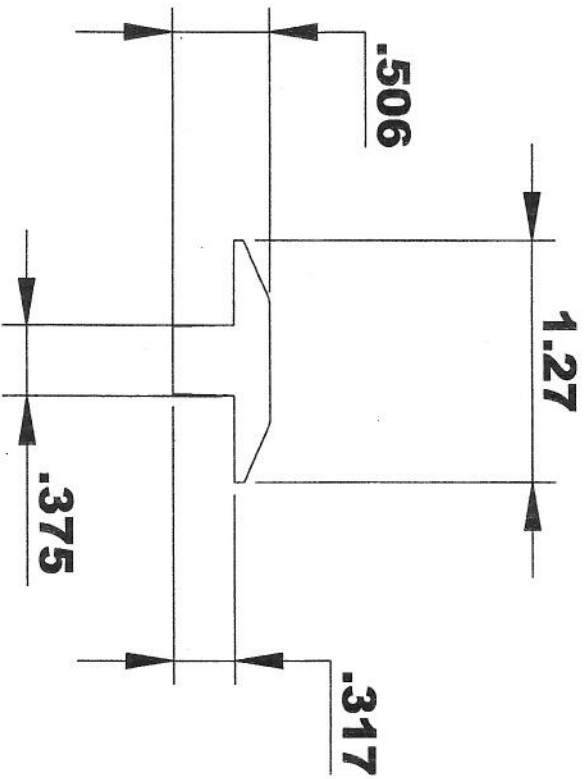

INSIDE OF MACHINE

OUTFEED VIEW COMING

SPECIFICATIONS

MOULDING # **PA 13**

CUSTOMER: _____

COMMENTS: **20* HOOK**

MOULDER: 5/16 T-REX CORR., 1.5 START DEPTH, 10MM AXIALS
T-REX LONG WEAR

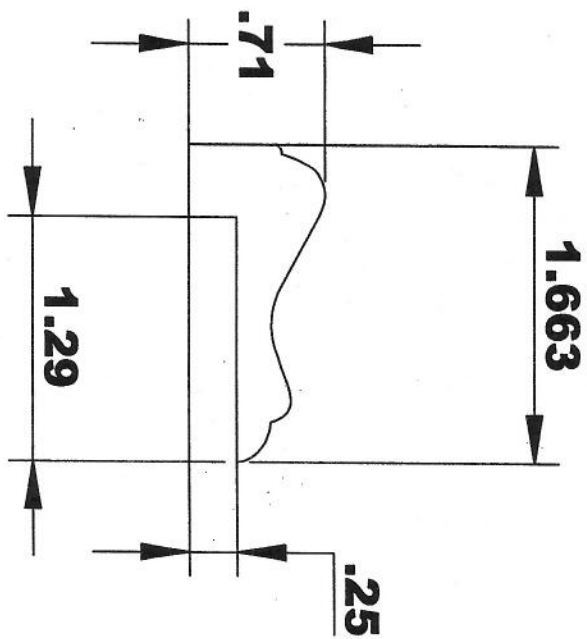

INSIDE OF MACHINE

OUTFEED VIEW COMING

SPECIFICATIONS

MOULDING # PA 14

CUSTOMER: _____

COMMENTS: 20* HOOK

MOULDER: 5/16 T-REX CORR., 1.5 START DEPTH, 10MM AXIALS

T-REX LONG WEAR

VARIABLE TILT RABBIT

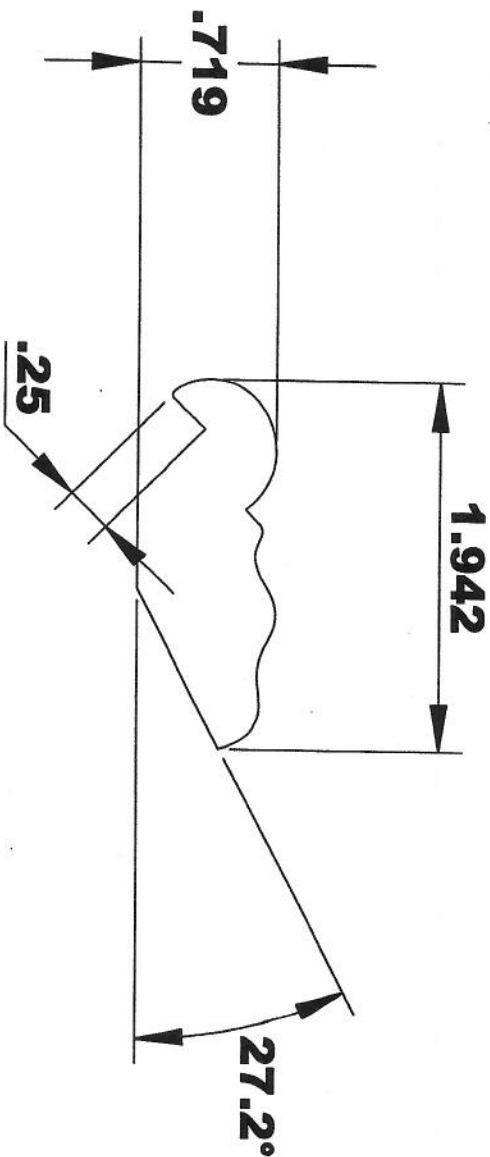
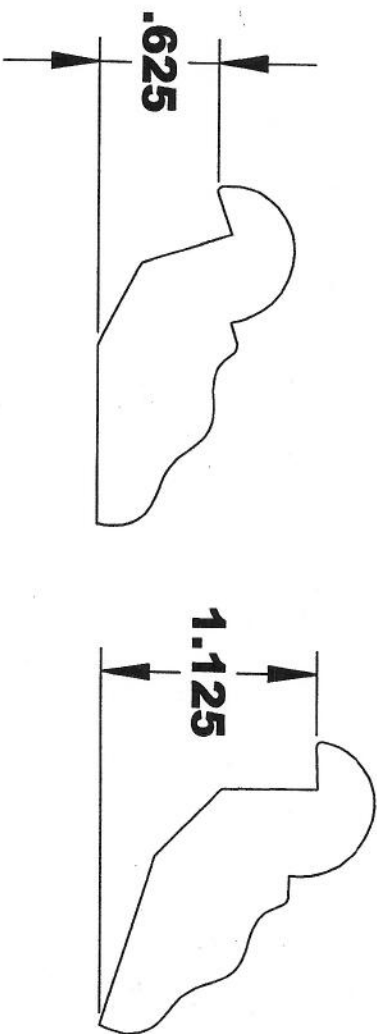

INSIDE OF MACHINE

OUTFEED VIEW COMING

SPECIFICATIONS

MOULDING # **PA 15**

CUSTOMER: _____

COMMENTS: **20* HOOK**

MOULDER: 5/16 T-REX CORR., 1.5 START DEPTH, 10MM AXIALS
T-REX LONG WEAR

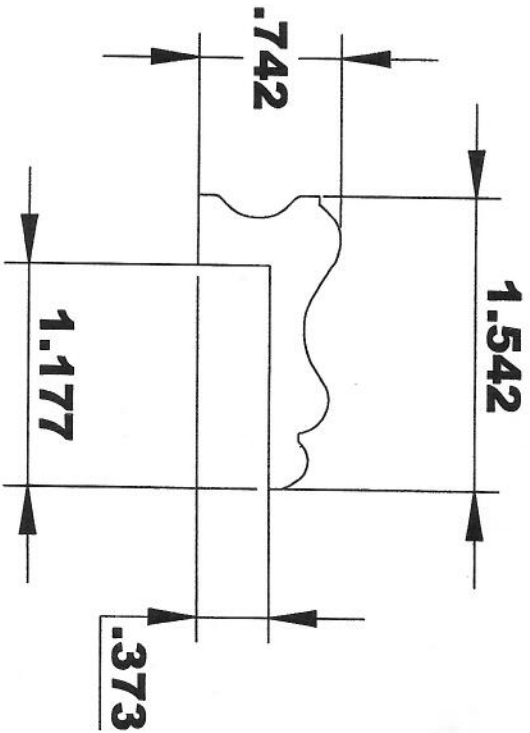

INSIDE OF MACHINE

OUTFEED VIEW COMING

SPECIFICATIONS

MOULDING # **PA 16**

CUSTOMER: _____

COMMENTS: **20* HOOK**

MOULDER: 5/16 T-REX CORR., 1.5 START DEPTH, 10MM AXIALS
T-REX LONG WEAR

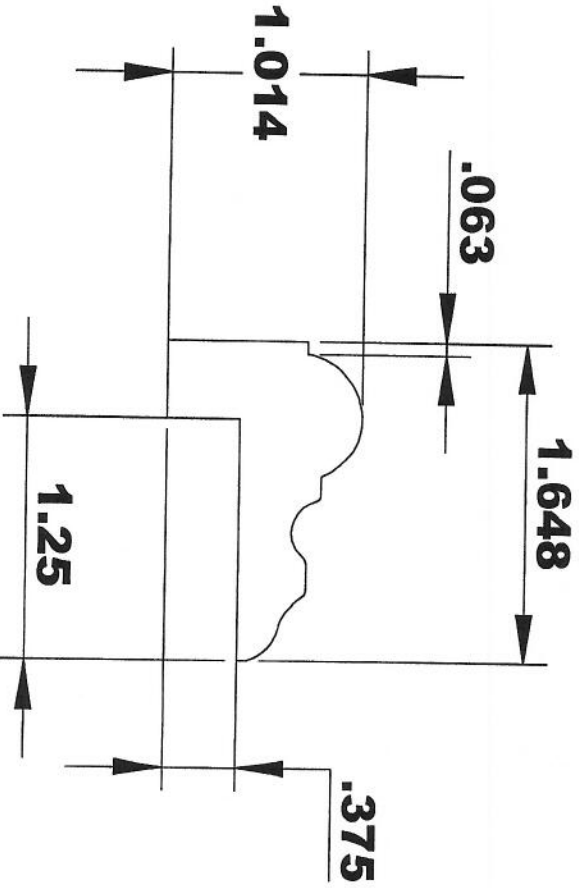

INSIDE OF MACHINE

OUTFEED VIEW COMING

SPECIFICATIONS

MOULDING # **PA 17**

CUSTOMER: _____

COMMENTS: **20* HOOK**

MOULDER: 5/16 T-REX CORR., 1.5 START DEPTH, 10MM AXIALS
T-REX LONG WEAR

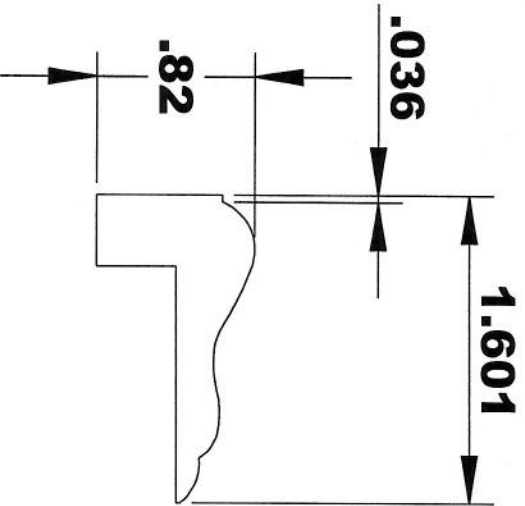

INSIDE OF MACHINE

OUTFEED VIEW COMING

SPECIFICATIONS

MOULDING # **PA 18**

CUSTOMER: _____

COMMENTS: **20 * HOOK**

MOULDER: 5/16 T-REX CORR., 1.5 START DEPTH, 10MM AXIALS
T-REX LONG WEAR

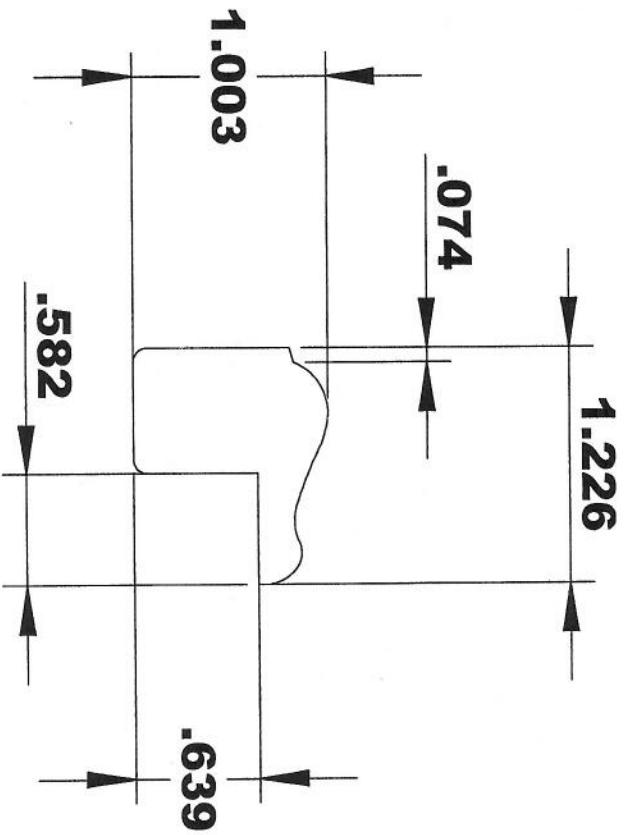

INSIDE OF MACHINE

OUTFEED VIEW COMING

SPECIFICATIONS

MOULDING # **PA 19**

CUSTOMER: _____

COMMENTS: **20 * HOOK**

MOULDER: 5/16 T-REX CORR., 1.5 START DEPTH, 10MM AXIALS

T-REX LONG WEAR

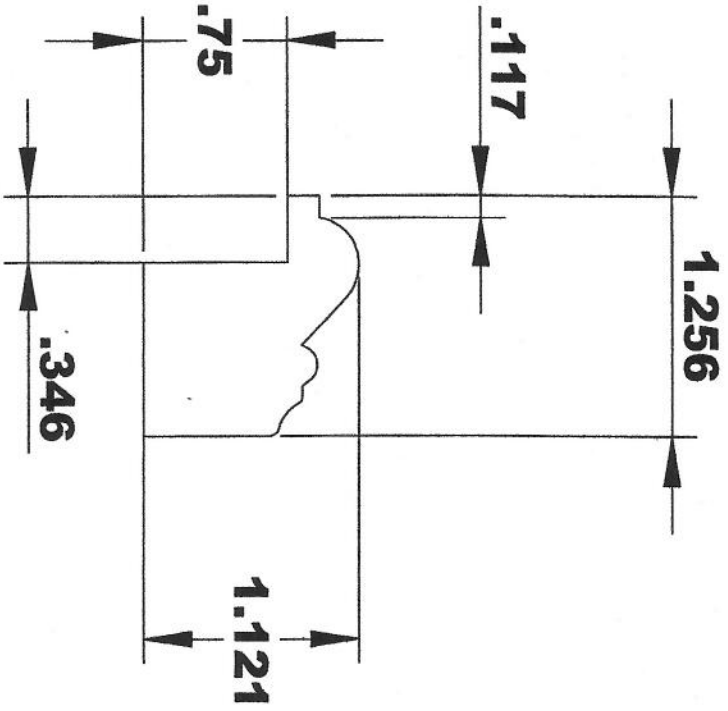

INSIDE OF MACHINE

OUTFEED VIEW COMING

SPECIFICATIONS

MOULDING # PA 20

CUSTOMER: _____

COMMENTS: 20* HOOK

MOULDER: 5/16 T-REX CORR., 1.375 START DEPTH, 10MM AXIALS
T-REX LONG WEAR

5/16 x 1 1/2

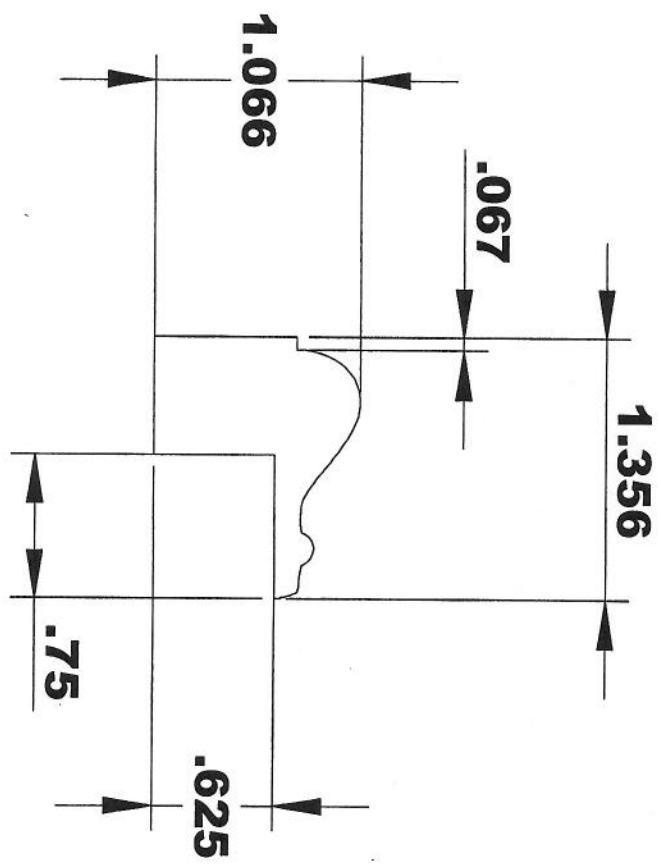

INSIDE OF MACHINE

OUTFEED VIEW COMING

SPECIFICATIONS

MOULDING # PA 21

CUSTOMER: _____

COMMENTS: 20* HOOK

MOULDER: 5/16 T-REX CORR., 1.375 START DEPTH, 10MM AXIALS
T-REX LONG WEAR

*\$45
set up*

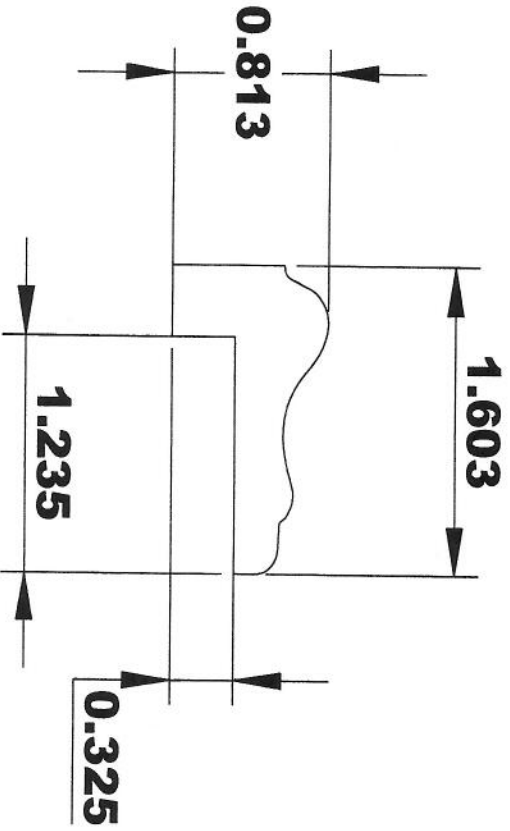

INSIDE OF MACHINE

OUTFEED VIEW COMING

SPECIFICATIONS

MOULDING # PL 1

CUSTOMER: _____

COMMENTS: 20* HOOK

MOULDER: 5/16 T-REX CORR., 1.5 START DEPTH, 10MM AXIALS
T-REX LONG WEAR

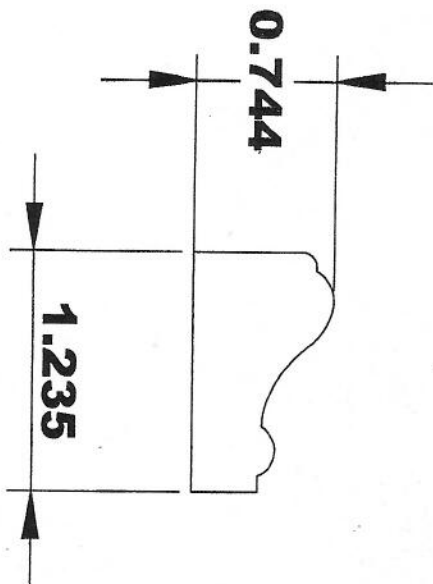

INSIDE OF MACHINE

OUTFEED VIEW COMING

SPECIFICATIONS

MOULDING # **PL 2**

CUSTOMER: _____

COMMENTS: **20* HOOK**

MOULDER: 5/16 T-REX CORR., 1.5 START DEPTH, 10MM AXIALS
T-REX LONG WEAR

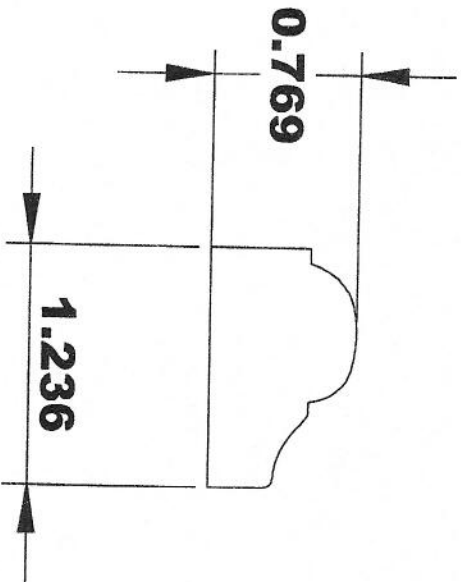

INSIDE OF MACHINE

OUTFEED VIEW COMING

SPECIFICATIONS

MOULDING # PL 3

CUSTOMER: _____

COMMENTS: 20 * HOOK

MOULDER: 5/16 T-REX CORR., 1.5 START DEPTH, 10MM AXIALS

T-REX LONG WEAR

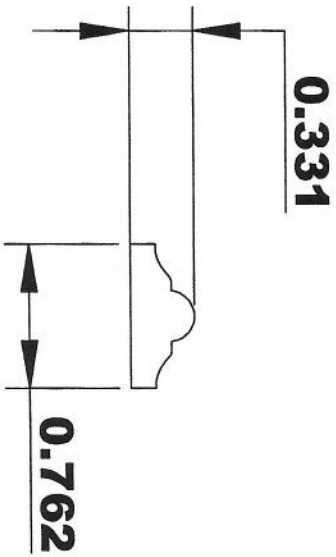

INSIDE OF MACHINE

OUTFEED VIEW COMING

SPECIFICATIONS

MOULDING # PL 4

CUSTOMER: _____

COMMENTS: 20* HOOK

MOULDER: 5/16 T-REX CORR., 1.5 START DEPTH, 10MM AXIALS

T-REX LONG WEAR

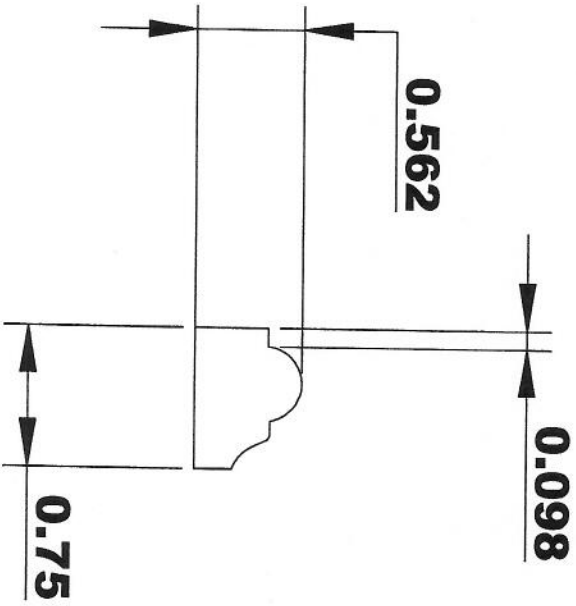

INSIDE OF MACHINE

OUTFEED VIEW COMING

SPECIFICATIONS

MOULDING # PL 5

CUSTOMER: _____

COMMENTS: 20* HOOK

MOULDER: 5/16 T-REX CORR., 1.5 START DEPTH, 10MM AXIALS
T-REX LONG WEAR

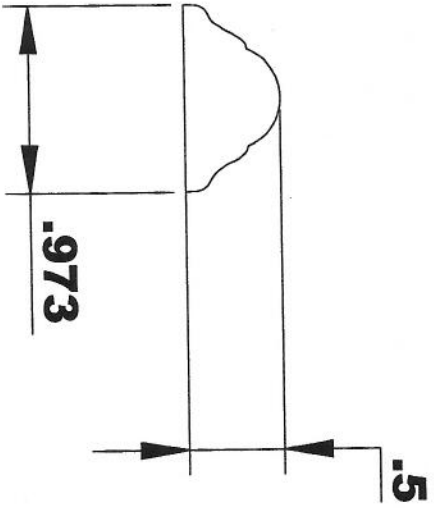

INSIDE OF MACHINE

OUTFEED VIEW COMING

SPECIFICATIONS

MOULDING # PL 6

CUSTOMER: _____

COMMENTS: 20 * HOOK

MOULDER: 5/16 T-REX CORR., 1.5 START DEPTH, 10MM AXIALS
T-REX LONG WEAR

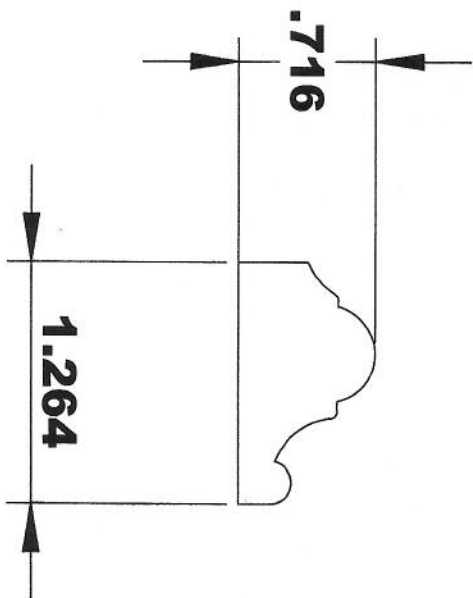

INSIDE OF MACHINE

OUTFEED VIEW COMING

SPECIFICATIONS

MOULDING # PL 7

CUSTOMER: _____

COMMENTS: 20* HOOK

MOULDER: 5/16 T-REX CORR., 1.5 START DEPTH, 10MM AXIALS
T-REX LONG WEAR

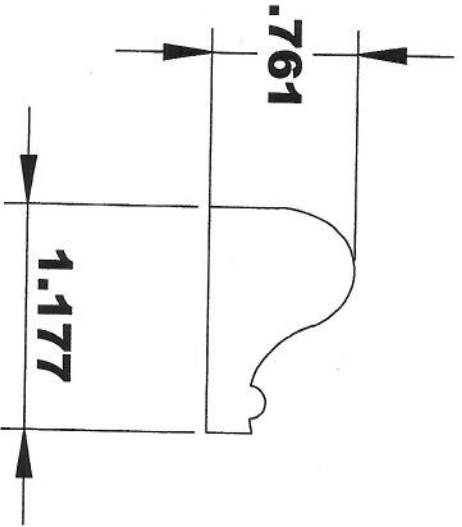

INSIDE OF MACHINE

OUTFEED VIEW COMING

SPECIFICATIONS

MOULDING # PL 8

CUSTOMER: _____

COMMENTS: 20* HOOK

MOULDER: 5/16 T-REX CORR., 1.5 START DEPTH, 10MM AXIALS
T-REX LONG WEAR

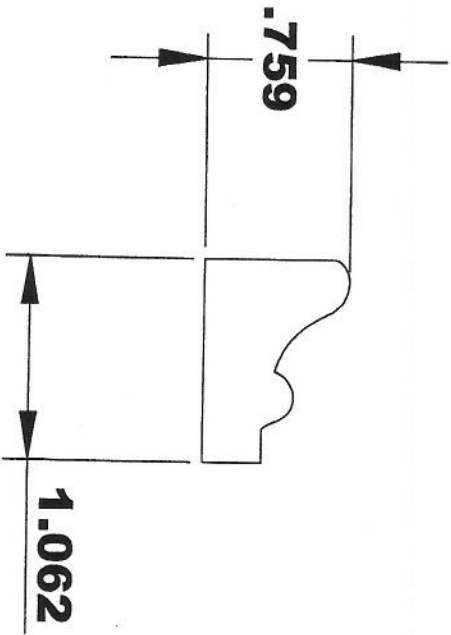

INSIDE OF MACHINE

OUTFEED VIEW COMING

SPECIFICATIONS

MOULDING # PL 9

CUSTOMER: _____

COMMENTS: 20 * HOOK

MOULDER: 5/16 T-REX CORR., 1.5 START DEPTH, 10MM AXIALS

T-REX LONG WEAR

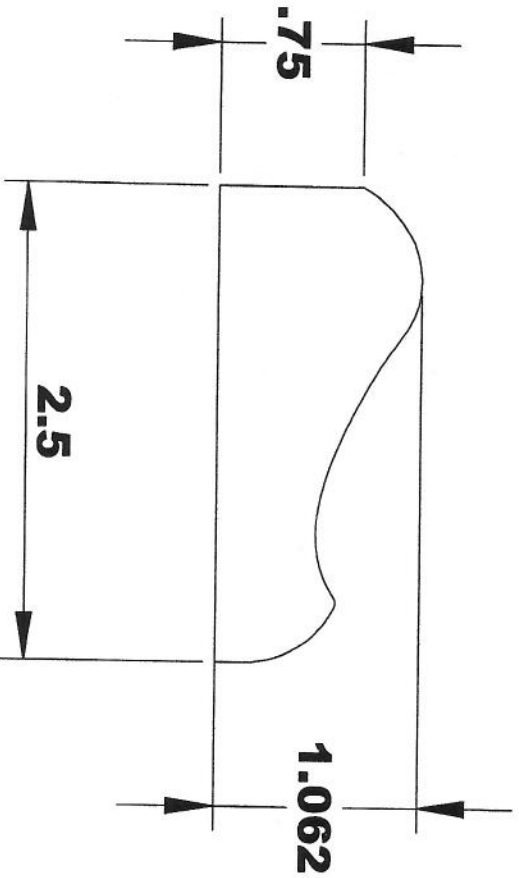

INSIDE OF MACHINE

OUTFEED VIEW COMING

SPECIFICATIONS

MOULDING # PL 10

CUSTOMER: _____

COMMENTS: 20* HOOK

MOULDER: 5/16 T-REX CORR., 1.5 START DEPTH, 10MM AXIALS

T-REX LONG WEAR

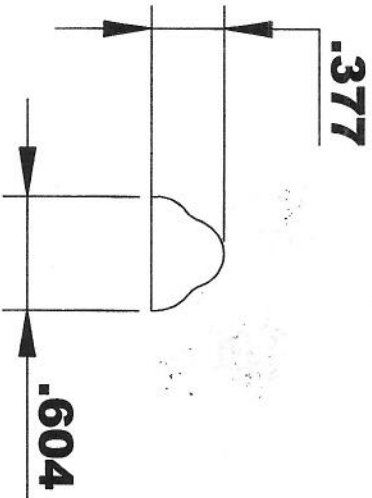

INSIDE OF MACHINE

OUTFEED VIEW COMING

SPECIFICATIONS

MOULDING # PL 10 DBL

CUSTOMER: _____

COMMENTS: 20* HOOK

MOULDER: 5/16 T-REX CORR., 1.5 START DEPTH, 10MM AXIALS
T-REX LONG WEAR

**CAUTION: KICK BACK HAZARD
MAY CAUSE INJURY OR DEATH
MUST USE OSHA APPROVED
ANTI-KICKBACK DEVICE**

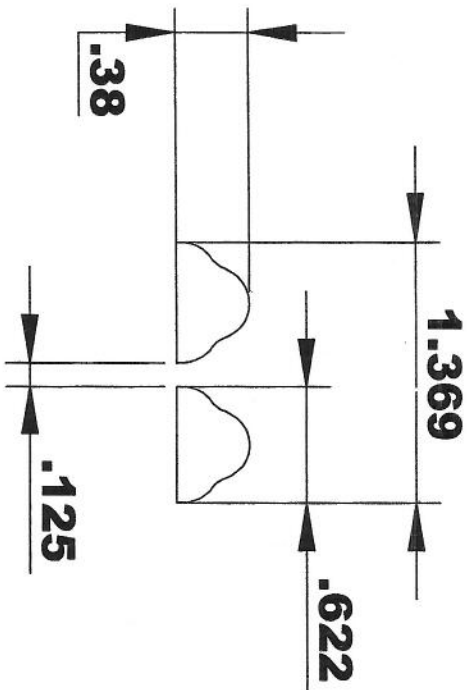

**KNIFE EXTENDS .010 INTO
ONION SKIN**

**DOUBLE SHIM LAST BOTTOM
STRAIGHT KNIVES TO REMOVE
.040 ONION SKIN**

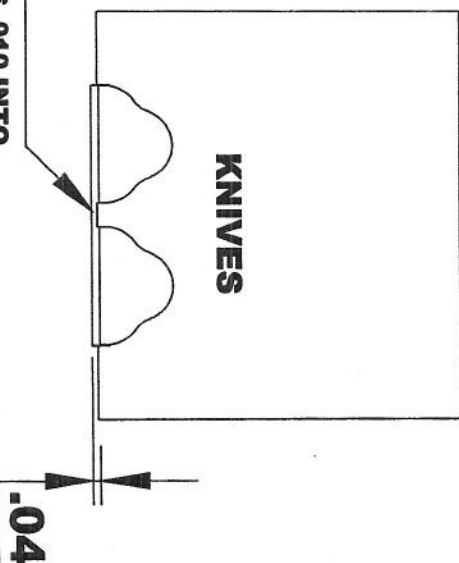

INSIDE OF MACHINE

OUTFEED VIEW COMING

SPECIFICATIONS

MOULDING # **PL 11**

CUSTOMER: _____

COMMENTS: **20° HOOK**

MOULDER: 5/16 T-REX CORR., 1.5 START DEPTH, 10MM AXIALS
T-REX LONG WEAR

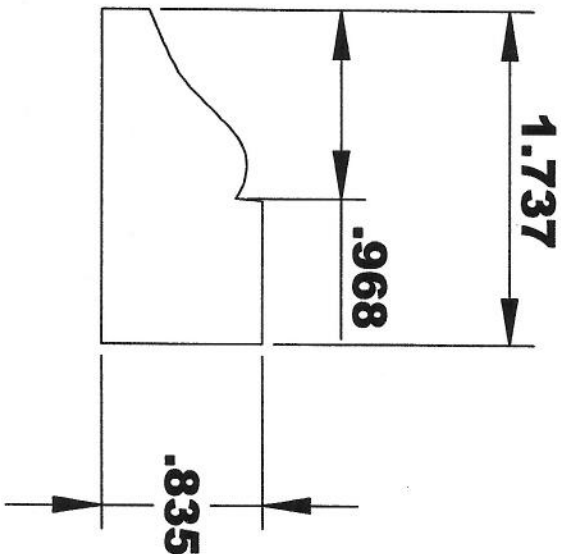

INSIDE OF MACHINE

OUTFEED VIEW COMING

SPECIFICATIONS

MOULDING # **PL 12**

CUSTOMER: _____

COMMENTS: **20* HOOK**

MOULDER: 5/16 T-REX CORR., 1.5 START DEPTH, 10MM AXIALS
T-REX LONG WEAR

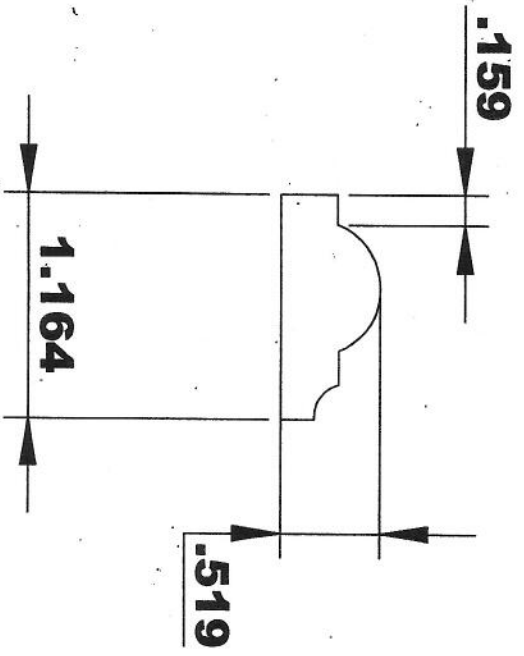

INSIDE OF MACHINE

OUTFEED VIEW COMING

SPECIFICATIONS

MOULDING # PL 13

CUSTOMER: _____

COMMENTS: 20 * HOOK

MOULDER: 5/16 T-REX CORR., 1.5 START DEPTH, 10MM AXIALS
T-REX LONG WEAR

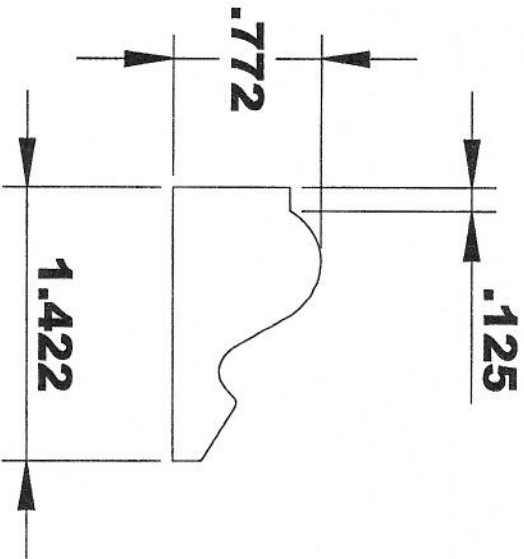

INSIDE OF MACHINE

OUTFEED VIEW COMING

SPECIFICATIONS

MOULDING # **PL 14**

CUSTOMER: _____

COMMENTS: **20* HOOK**

MOULDER: 5/16 T-REX CORR., 1.5 START DEPTH, 10MM AXIALS

T-REX LONG WEAR

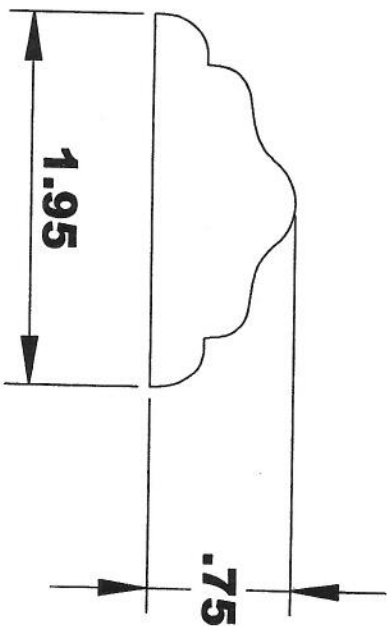

NOTE: MAKE SYMMETRICAL

INSIDE OF MACHINE

OUTFEED VIEW COMING

SPECIFICATIONS

MOULDING # **PL 15 DBL**

CUSTOMER: _____

COMMENTS: **20* HOOK**

MOULDER: 5/16 T-REX CORR., 1.5 START DEPTH, 10MM AXIALS
T-REX LONG WEAR

**CAUTION: KICK BACK HAZARD
MAY CAUSE INJURY OR DEATH
MUST USE OSHA APPROVED
ANTI-KICKBACK DEVICE**

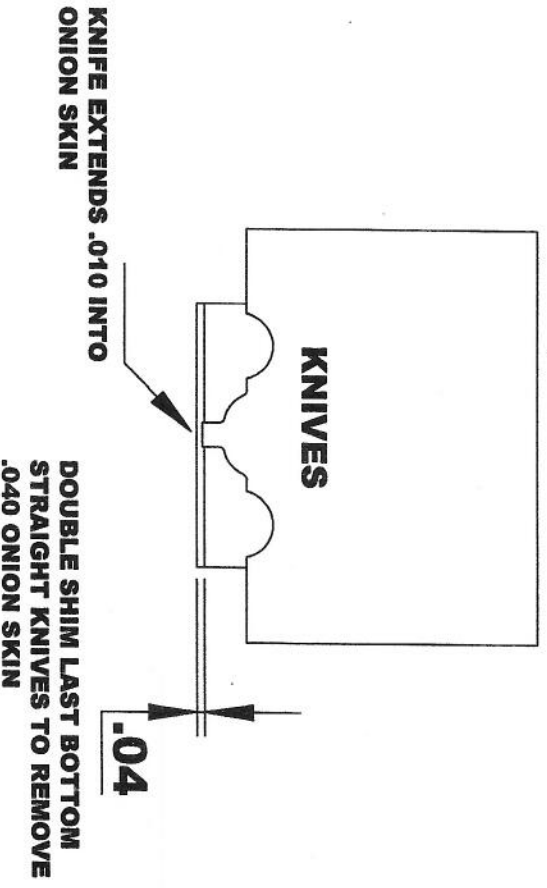
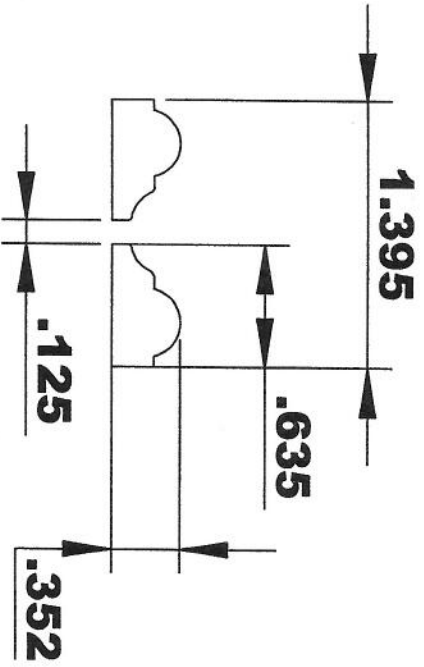

INSIDE OF MACHINE

OUTFEED VIEW COMING

SPECIFICATIONS

MOULDING # PL 16

CUSTOMER: _____

COMMENTS: 20° HOOK

MOULDER: 5/16 T-REX CORR., 1.5 START DEPTH, 10MM AXIALS
T-REX LONG WEAR

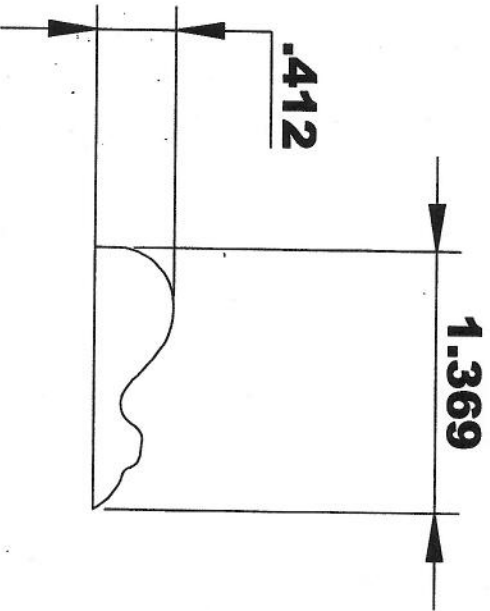

INSIDE OF MACHINE

FEED VIEW COMING

SPECIFICATIONS

MOULDING # PL 17

CUSTOMER: _____

COMMENTS: 20* HOOK

MOULDER: 5/16 T-REX CORR., 1.5 START DEPTH, 10MM AXIALS
T-REX LONG WEAR

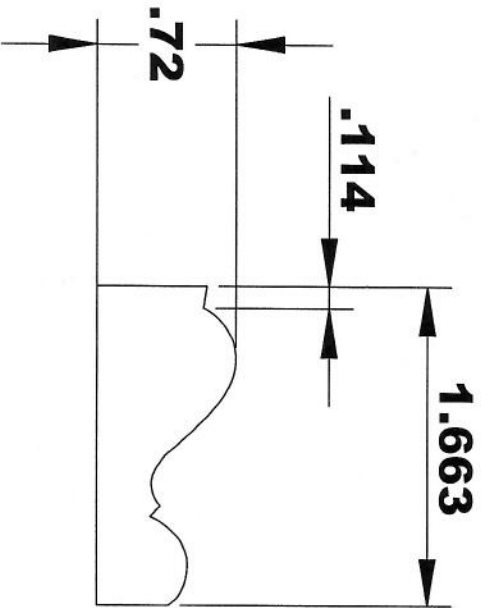

INSIDE OF MACHINE

OUTFEED VIEW COMING

SPECIFICATIONS

MOULDING # **PL 18**

CUSTOMER: _____

COMMENTS: **20 * HOOK**

MOULDER: 5/16 T-REX CORR., 1.5 START DEPTH, 10MM AXIALS
T-REX LONG WEAR

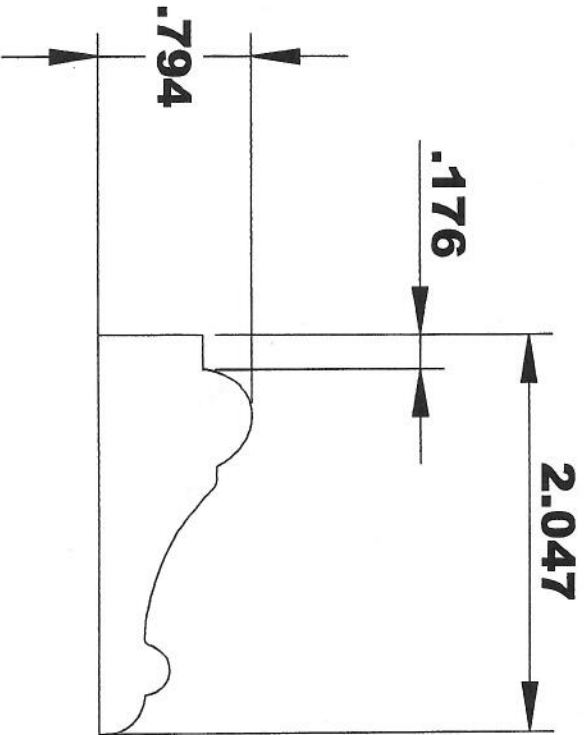

INSIDE OF MACHINE

OUTFEED VIEW COMING

SPECIFICATIONS

MOULDING # PL 19

CUSTOMER: _____

COMMENTS: 20* HOOK

MOULDER: 5/16 T-REX CORR., 1.5 START DEPTH, 10MM AXIALS
T-REX LONG WEAR

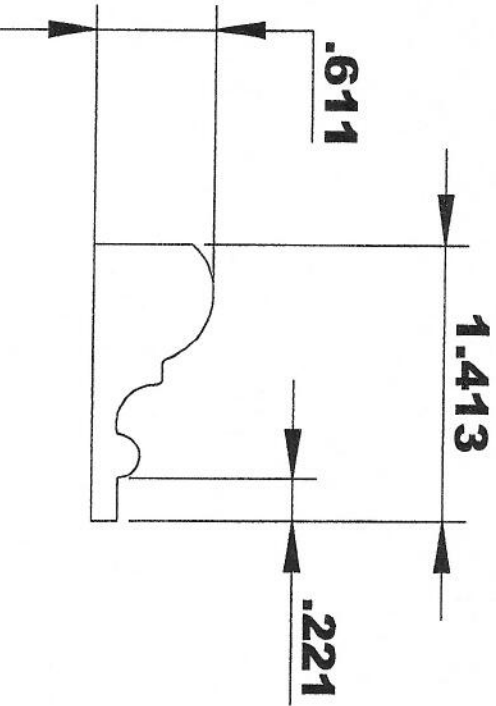

INSIDE OF MACHINE

OUTFEED VIEW COMING

SPECIFICATIONS

MOULDING # **PL 20**

CUSTOMER: _____

COMMENTS: **20* HOOK**

MOULDER: 5/16 T-REX CORR., 1.5 START DEPTH, 10MM AXIALS
T-REX LONG WEAR

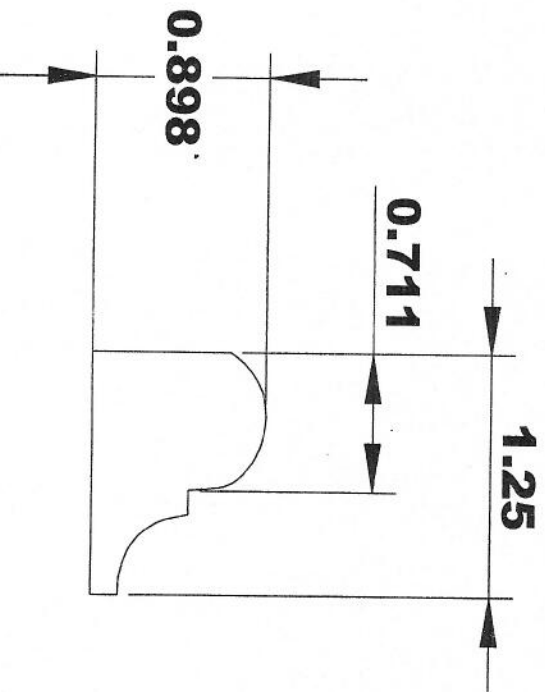

INSIDE OF MACHINE

OUTFEED VIEW COMING

SPECIFICATIONS

MOULDING # **PL 20 A**

CUSTOMER: _____

COMMENTS: **20 * HOOK**

MOULDER: 5/16 T-REX CORR., 1.375 START DEPTH, 10MM AXIALS
T-REX LONG WEAR

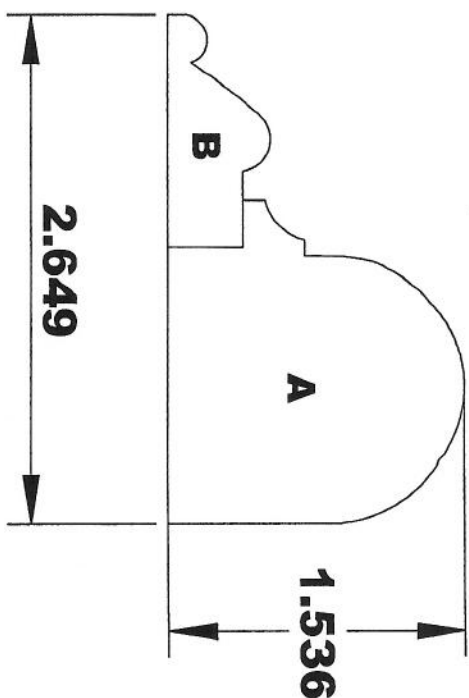
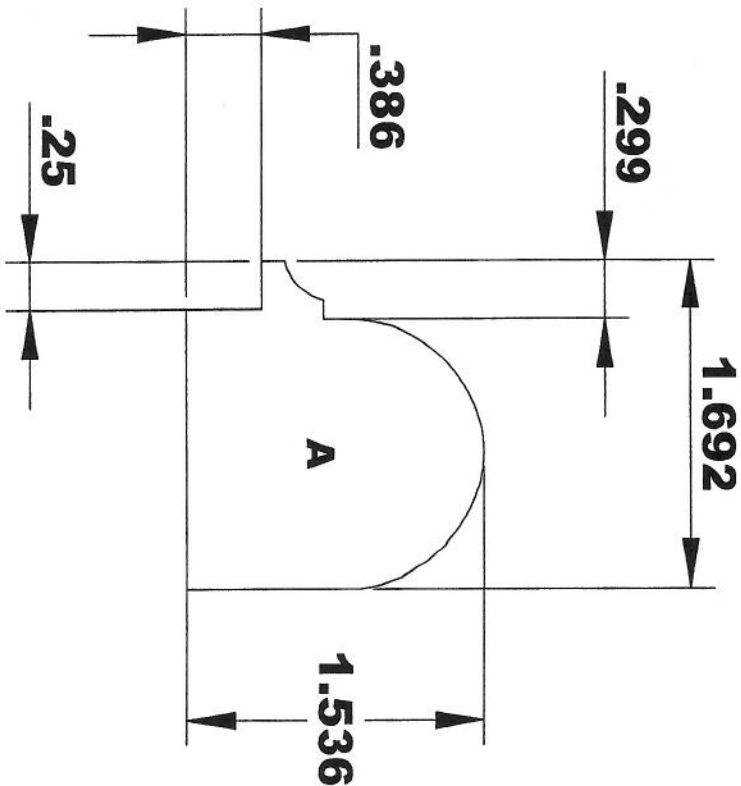

INSIDE OF MACHINE

OUTFEED VIEW COMING

SPECIFICATIONS

MOULDING # **PL 20 B**

CUSTOMER: _____

COMMENTS: **20 * HOOK**

MOULDER: 5/16 T-REX CORR., 1.375 START DEPTH, 10MM AXIALS
T-REX LONG WEAR

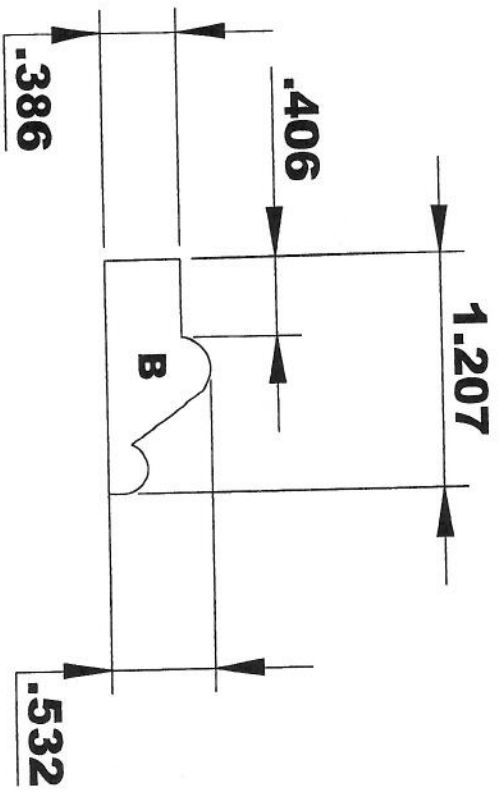
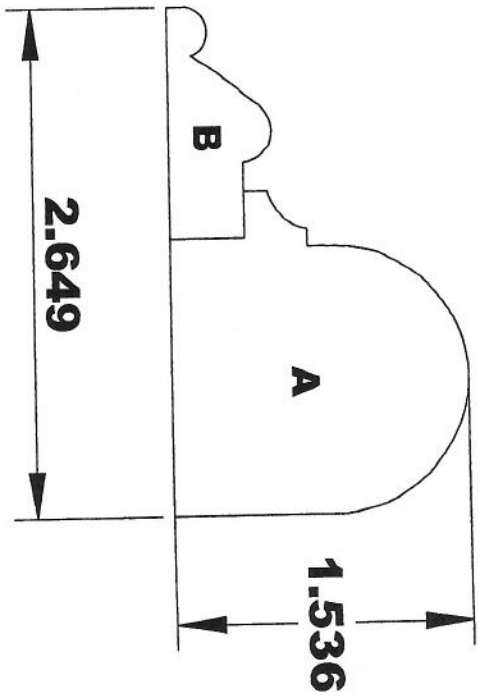

INSIDE OF MACHINE

OUTFEED VIEW COMING

SPECIFICATIONS

MOULDING # PL 21

CUSTOMER: _____

COMMENTS: 20 * HOOK

MOULDER: 5/16 T-REX CORR., 1.375 START DEPTH, 10MM AXIALS
T-REX LONG WEAR

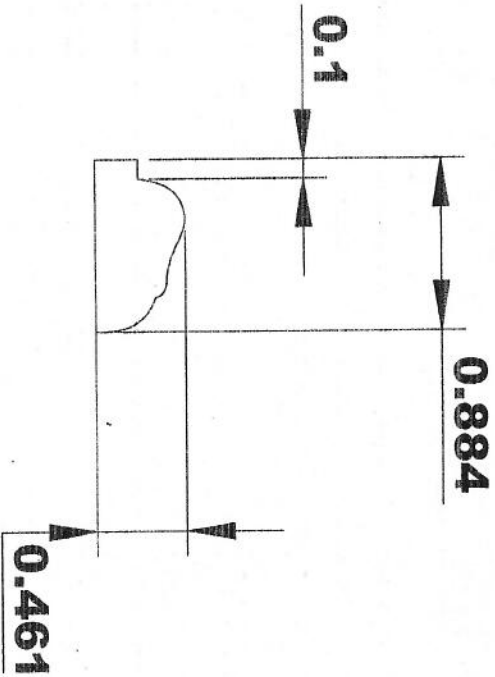

INSIDE OF MACHINE

OUTFEED VIEW COMING

SPECIFICATIONS

MOULDING # PL 22

CUSTOMER: _____

COMMENTS: 20* HOOK

MOULDER: 5/16 T-REX CORR., 1.375 START DEPTH, 10MM AXIALS
T-REX LONG WEAR

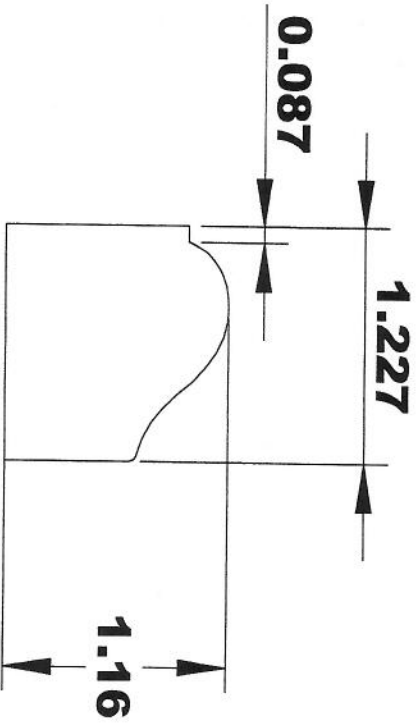

INSIDE OF MACHINE

OUTFEED VIEW COMING

SPECIFICATIONS

MOULDING # **DR STP 1**

CUSTOMER: _____

COMMENTS: **20° HOOK**

MOULDER: 5/16 T-REX CORR., 1.5 START DEPTH, 10MM AXIALS
T-REX LONG WEAR

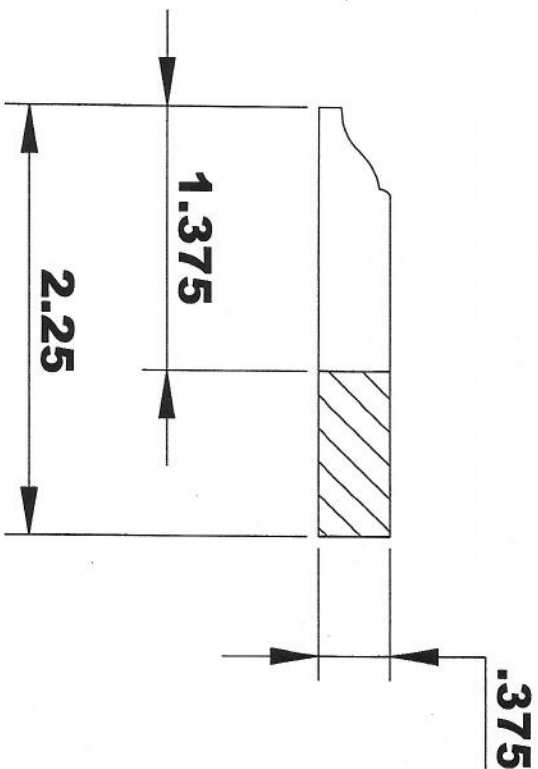

INSIDE OF MACHINE

OUTFEED VIEW COMING

SPECIFICATIONS

MOULDING # **TS-CH 40**

CUSTOMER: _____

COMMENTS: **20* HOOK**

MOULDER: 5/16 T-REX CORR., 1.5 START DEPTH, 10MM AXIALS
T-REX LONG WEAR

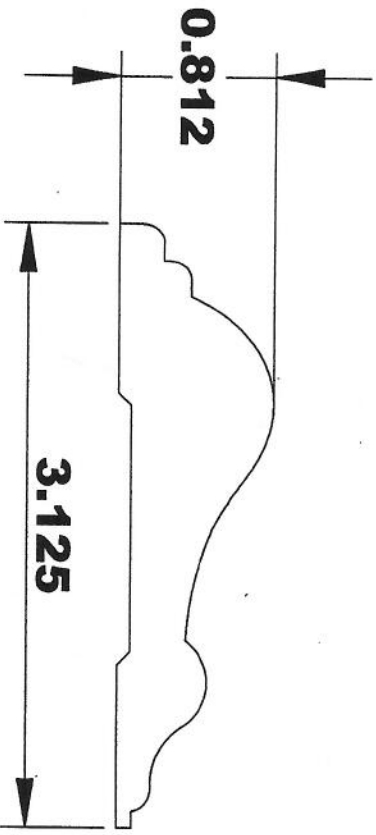

INSIDE OF MACHINE

OUTFEED VIEW COMING